

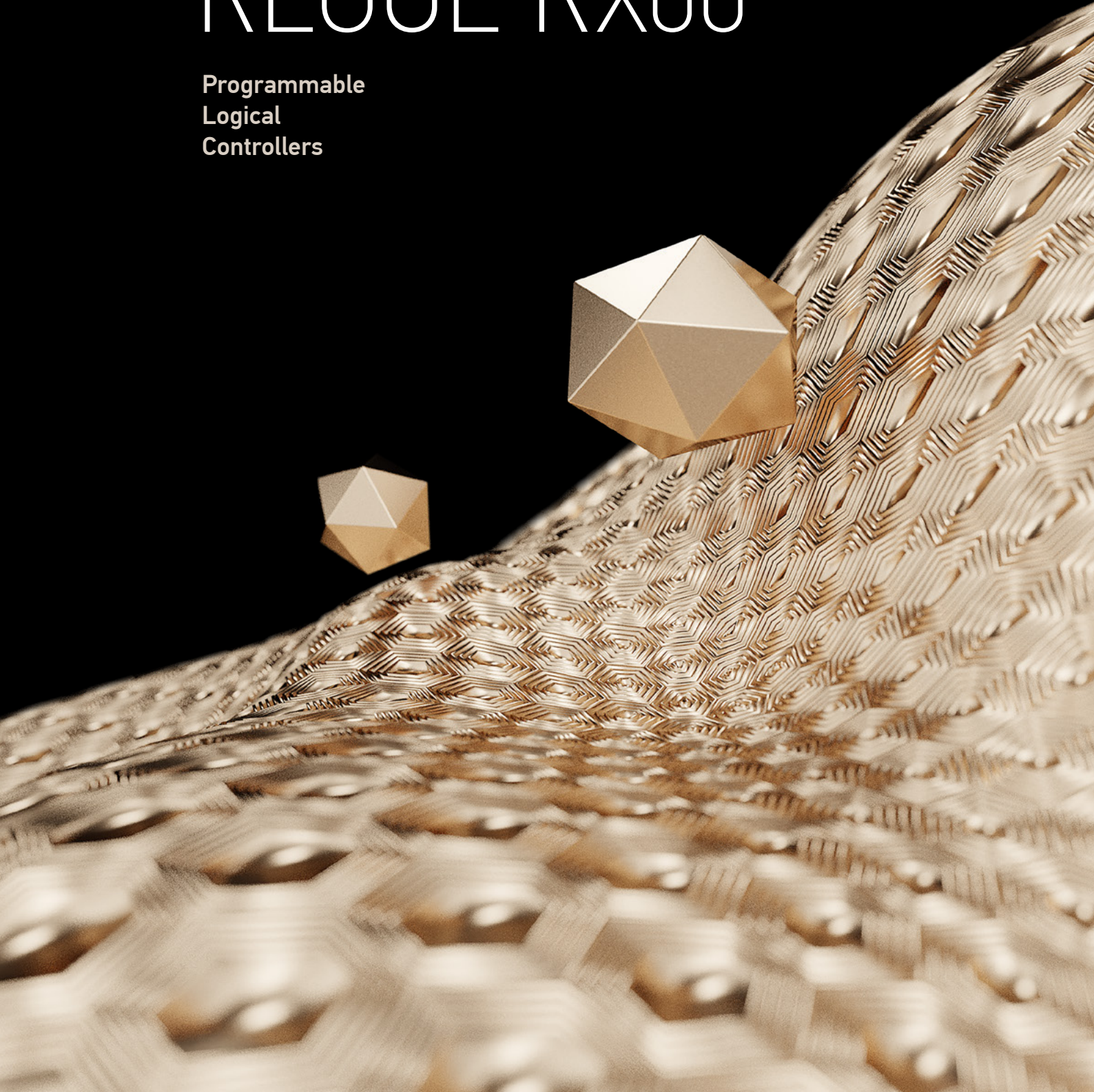

# REGUL RX00

Programmable  
Logical  
Controllers





# CONTENTS

## FEATURES OF THE REGUL RX00 PLC SERIES

### REDUNDANCY AT THE CORE

- Regul Controllers (series R500 and R600) Were Designed for Hardware Redundancy..... 6

### EXTRA FUNCTIONALITY

- Regul Controllers Have Extras on Board..... 8

### TIME STAMPING

- Accurate Time Stamping Means Correct History of the Events ..... 9

### FLEXIBILITY IN CONNECTING RACKS

- High Flexibility in Physical Communications Provides More Opportunities ..... 10

### INTEGRATED COMMUNICATION PROTOCOLS

- More Protocols to Connect to Third-party Devices and Systems ..... 11

## EXAMPLES OF APPLICATIONS: OIL AND GAS ..... 13

- Fiscal Metering – Control System for Lease Automatic Custody Transfer (LACT) Units ..... 14
- Control Systems for Oil Pumping Stations and Tank Farms ..... 16
- Fire and Gas Control System..... 18
- Telemetry Solution..... 20

## EXAMPLES OF APPLICATIONS: POWER INDUSTRY ..... 21

- Turbine and Auxiliary Equipment Control System ..... 22
- Electric Part of the Turbine Control and Protection System ..... 24
- Automatic Load-Frequency Control System ..... 25
- Turbo Generator Vibration Monitoring System..... 27
- Two-Axle Gas Turbine Control System ..... 28
- Boiler Control System..... 29

## SOLUTIONS

- Control System for Gas Pressure Regulators..... 34
- Gas Odorizing Unit Control System ..... 36
- Electronic Overspeed Trip for Steam and Gas Turbines ..... 37
- Industrial Converter Gateway..... 38

## REGUL RX00 PLC SERIES

- REGUL R600 Programmable Logic Controller..... 40
- REGUL R500 Programmable Logic Controller..... 46
- REGUL R400 HMI/Programmable Logic Controller ..... 55
- REGUL R200 Programmable Logic Controller..... 57
- REGUL R500S Safety (SIL3) Programmable Logic Controller ..... 62
- REGUL R000 Managed Switch ..... 64
- EPSILON LD – IEC 61131-3 Development Software for REGUL Controllers ..... 66
- AlfaRegul Integrated Control System (SCADA + HMI + PLC)..... 68

## TECHNICAL SUPPORT ..... 73

## TRAINING CENTER ..... 74





FEATURES  
OF THE  
REGUL RX00  
PLC SERIES

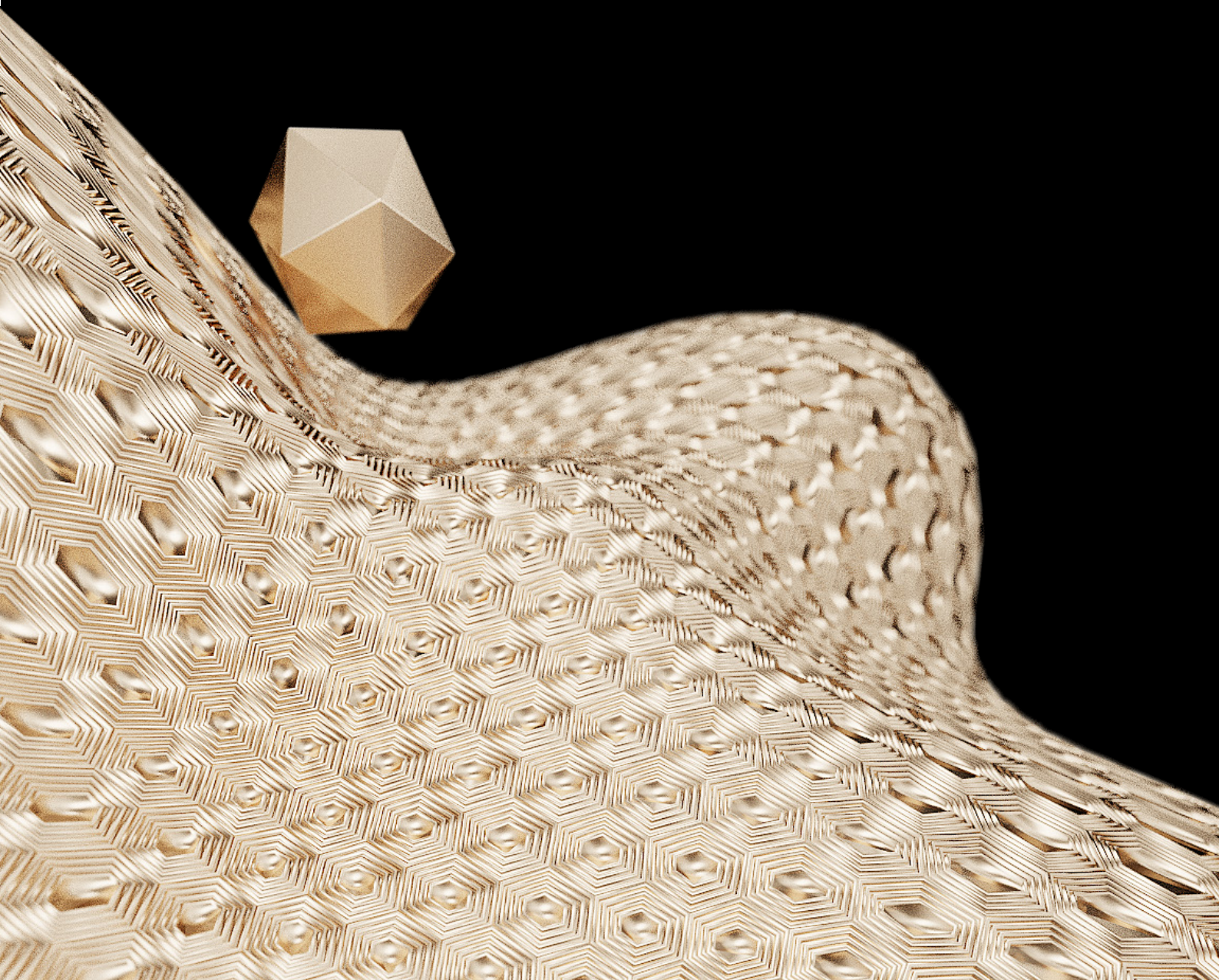

# REDUNDANCY AT THE CORE

## Regul Controllers (Series R500 and R600) Were Designed for Hardware Redundancy

### Real-Time

First things first, Regul controllers run on a real-time operating system and have a clear distinction between the real-time part and non-real-time operating part. With the first having complete priority over the processing power.

### Bus Redundancy

Regul bus is bi-directional, meaning that it can operate in both directions. In case of a failure the remaining segments around the fault are used to communicate data back to the CPU.

### Dual Ring Bus

Regul R500 and R600 have chassis and extension modules to create a dual ring. In case of a failure in one ring, controllers switch to using the second one. In particular configurations, the system can even tolerate up to three failures in the bus communications.

### Hot Swapping

Every module operates on a chassis, delivering power and bus communications. Removal of one of the modules keeps the system running.

### Hot-Standby CPU

CPU modules in the controllers execute application in parallel, reducing time required to process inputs and write outputs. The design of the Regul R500 and R600 controllers was done in a way that delivers a switchover within 1-2 application cycles.

### Dual CPU Sync

Any of the communication ports on the CPU modules can be used for synchronization, with two connections between CPU modules. Be it Ethernet or fiberoptic connection. The latter even allows you to put CPU modules into different buildings.

### Dual SCADA Connection

Any of the remaining communication ports on the CPU modules can be used for communication with SCADA, with the maximum speed of 1 Gbps.

### Output Strategies in Case of Lost Communication

Output modules can send a signal (analog modules) or a sequence of signals (digital modules) when all the communication to both CPU modules is lost. This is done to allow safe operation of the critical equipment or to command shutdown procedure (s).

### Multiple Power Supply Units

Power supply modules were designed to provide all modules with the power from the available power supplies. This means that the number can be 2-3 or more power supply modules per rack, depending on the power required and failure of how many you can tolerate.

## Redundant System Configurations

Duplicate (Mirror)

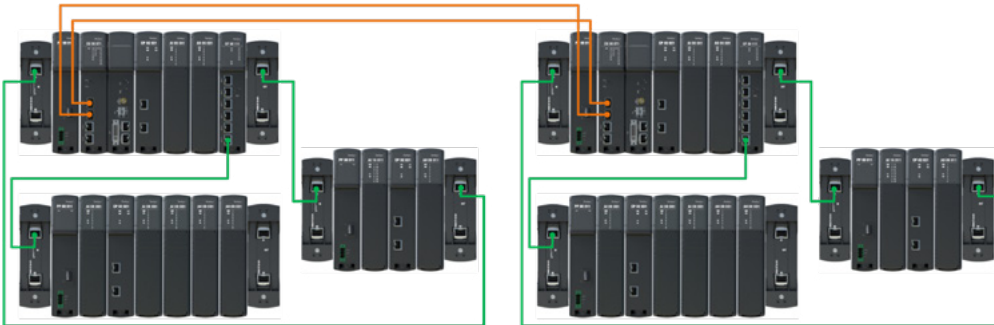

CPU and Bus Redundancy

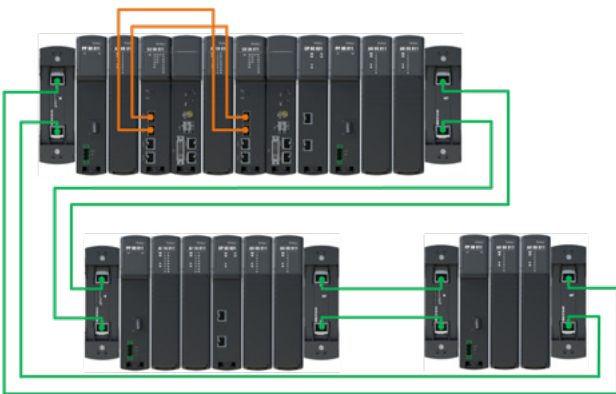

Redundant CPU with Shared I/Os

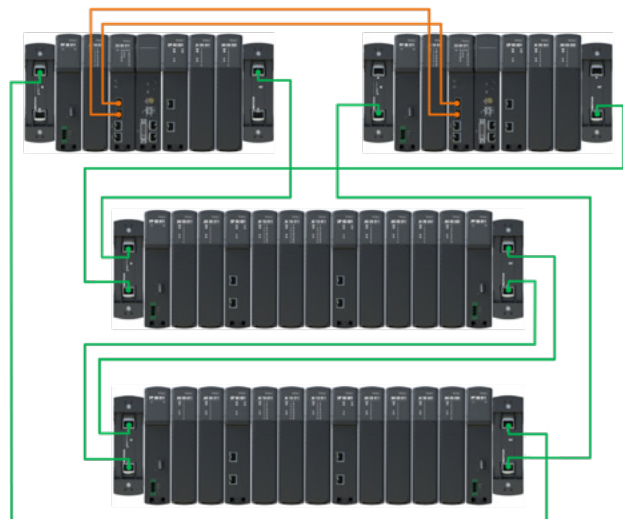

Multi-Series Redundant System

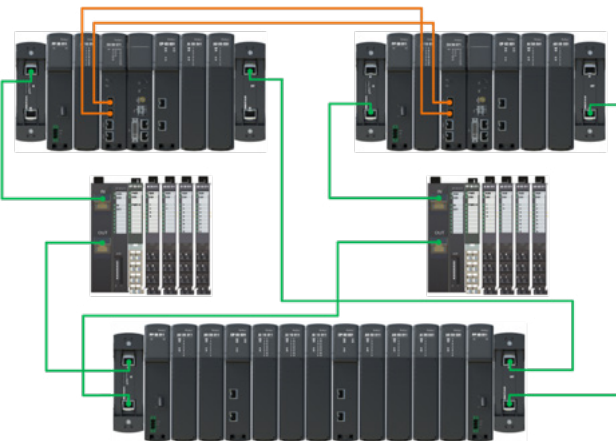



# EXTRA FUNCTIONALITY

## Regul Controllers Have Extras on Board

### Large Amount of Memory

In certain cases, communication channels may lack stability, requiring controller to store the data until connection is re-established properly, that may take long time. To avoid loss of data, Regul controllers have significant size of Flash/SSD storage on board to allow for it.

### MySQL Database

Some applications require additional archiving on the PLC. For this purpose, there are versions (Regul R500/R600) with MySQL database.

### DVI/VGA Output and USB Ports

In some cases, an external monitor must be connected directly to the PLC to monitor the data on it. And a keyboard with a printer can be used without installing an additional HMI.

### Web HMI

There is an option of CPU modules to come with pre-installed Web server. HMI for the Web server is prepared in the Epsilon LD software and accessed via a web browser.

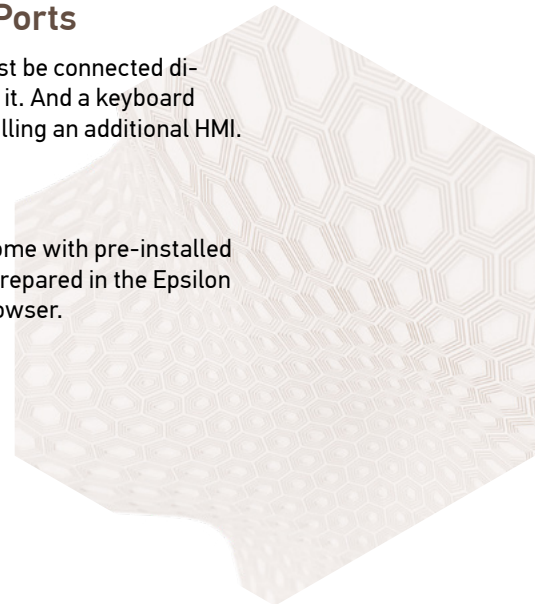



# TIME STAMPING

## Accurate Time Stamping Means Correct History of the Events

### Integrated GPS/Glonass Receivers

CPU module in every series of the Regul controllers carries an integrated GPS/Glonass receivers to have correct and independent synchronization of the internal clock.

### Time Server in CPU Modules

The approach that we selected was to implement time server into the CPU modules that can sync itself to the integrated GPS/Glonass receiver or to an external time server of your choice.

### Time Stamping in the I/O Modules

Each I/O module has an internal clock that is synchronized with the clock in the CPU module and time stamps each received event. This happens by the module, before communication event data to the CPU. On top of this, digital modules also store internally received events.

### NTP and PTP Protocols

For synchronization with third-party time servers Regul controllers have integrated NTP and PTP protocols in the CPU modules.

# FLEXIBILITY IN CONNECTING RACKS

## High Flexibility in Physical Communications Provides More Opportunities

### Copper or Fiberoptics

While Regul bus is the logical level, it can operate on copper or fiberoptic physical level. Type of medium between the racks is defined by the type of selected termination modules.

### Single Mode or Multi Mode

Type of fiberoptic connection depends purely on the adapter you select.

### Rack Connection Types

Regul controllers are capable of operation in several configurations of the racks:

- Line
- Ring
- Star
- Daisy chain
- Dual ring

### Segmenting

Use of communication processor modules allows you to create additional segments in the control system. The segments, that you can switch on and off on demand to improve reliability and diagnostics of the system.

### Off-the-shelf Adapters and Cables

Both types of termination modules provide ports for connecting Ethernet cable with connector or a fiberoptic adapter. The choice is recommended to in line with tested adapters from the commonly available on the market.

# INTEGRATED COMMUNICATION PROTOCOLS

## More Protocols to Connect to Third-party Devices and Systems

### **Modbus RTU and Modbus TCP**

Commonly used protocols to connect with third-party systems and devices in the field.

### **OPC DA and OPC UA**

Protocols to communicate with servers and SCADA systems, promoted by OPC Foundation. Certified compliance for Regul R500 in the Baden-Württemberg laboratory of the Foundation.

### **IEC 60870-5-101 and IEC 60870-5-104**

Family of the protocols commonly used in the power industry.

### **Other**

Regul controllers also have support for TCP/IP, FTP, UDP and other protocols.





# EXAMPLES OF APPLICATIONS: OIL AND GAS

Automation in oil and gas industry presents strict requirements to the reliability of the programmable logic controllers (PLCs) and to their technical specifications. Regul RX00 PLCs comply with everything that the industry requires, delivering stable and continuous control of the operations, withstanding multiple faults in the system, and pioneering flexible system design and communication among interconnected subsystems in the field.

Digital input modules have Sequence of Events capability built-in by default, to analyze events in the system step-by-step without impact of the communication lines. Output modules can be configured for the strategies to properly shutdown the underlying system (s) in case of complete loss of communication.

Extension with the integrated AlfaRegul SCADA brings in redundant servers for operational control, trends, alarms, events, historical data, in-house developed noSQL database optimized for time series. Cascade regulation in the systems is available both at the controller level or through the centralized control from AlfaRegul.

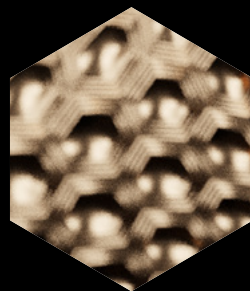
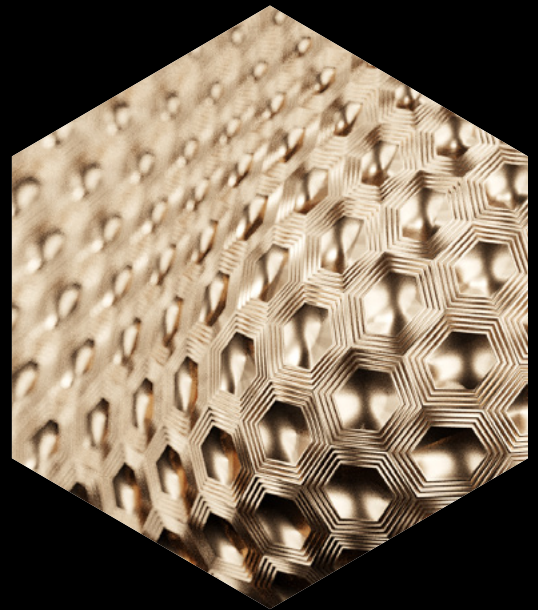

# Fiscal Metering – Control System for Lease Automatic Custody Transfer (LACT) Units

With the focus in the oil & gas industry shifting from exploration to optimizing current operations, Lease Automatic Custody Transfer (LACT) units come forward in increasing efficiency of the oil transfer and providing more accurate accounting, collected at the SCADA level.

The system is an improved-accuracy fiscal metering system for LACT units, able to measure, compute, and store data on oil:

- Volume
- Quality (density, viscosity, humidity)
- Flow
- Pressure and pressure drops
- Temperature

The system is made of a PLC (R600, R500, or combination of R400 HMI with R200 modules), high-accuracy analog input modules (AI 08041 or AI 02041) with just a 0.025% margin of error, and a specialized I/O module with integrated algorithm for LACT units (DA 03011/DA 01011). The use of the latter modules ensures calibration unit control and the reception of the signals from flow meters in a timely and accurate manner.

To the system could be connected external devices, like a printer, for example, via USB ports, monitors via VGA (R600) or DVI (R500) interfaces on the CPU modules.

The entire visualization process for the system is implemented in one project together with the preset functions. All the information from the REGUL RX00 controllers is communicated to the redundant servers and to the LACT unit workstation. The system could be connected to most major SCADA systems available on the market.

When using R200 I/O modules, additional protective seals could be added, to protect against unauthorized module replacement.

**Technical specifications (depending on the system's type of built-in software)**

<b>General</b>	Configuration options:	
	Measurement lines	12
	Density transducer types	<ul style="list-style-type: none"> <li>• pulse (Solartron, Sarasota)</li> <li>• analog</li> </ul>
	Flow transducer types	<ul style="list-style-type: none"> <li>• mass</li> <li>• volume</li> <li>• ultrasound</li> </ul>
	Calibration specifications of the flow transducers	<ul style="list-style-type: none"> <li>• constant ratios in the working range</li> <li>• constant ratios in subranges</li> <li>• piecewise linear approximation</li> </ul>
	Calibration settings	<ul style="list-style-type: none"> <li>• unidirectional</li> <li>• bidirectional</li> <li>• compact provers</li> </ul>
	Electrical supply	
	<ul style="list-style-type: none"> <li>• Current type</li> <li>• Voltage</li> </ul>	<p>DC 24V</p>
	Operating environment	
	<ul style="list-style-type: none"> <li>• Ambient temperatures</li> <li>• Relative humidity</li> <li>• Atmospheric pressure range</li> </ul>	<p>+10°C ... +40°C 35-70% 84-106.7 kPa</p>
<b>Basic metrological specifications</b>	Relative error of input signal measurement	
	<ul style="list-style-type: none"> <li>• DC</li> <li>• In the frequency mode</li> <li>• In the pulse count mode</li> <li>• Absolute error of density calculation</li> </ul>	<p>&lt;0.025% &lt;0.01% &lt;1 pulse &lt;0.01 kg/m<sup>3</sup></p>
	Relative error of software and data-processing algorithms	
	<ul style="list-style-type: none"> <li>• Oil mass calculation</li> <li>• Oil volume calculation</li> <li>• Working flow transducer ratio</li> </ul>	<p>&lt;0.002% &lt;0.0004% &lt;0.025%</p>
	Relative error of measurement of	
<ul style="list-style-type: none"> <li>• Oil gross weight</li> <li>• Oil net weight</li> <li>• Oil volume</li> </ul>	<p>&lt;0.05% &lt;0.05% &lt;0.025%</p>	
<b>Calibration methods</b>	<p>Pipe/piston calibration unit of Grade One with a MI 2974-2006 comparator</p> <ul style="list-style-type: none"> <li>• MI 1974-2004 turbine flow transducers</li> <li>• MI 3380-2012 volume flow transducers</li> <li>• MI 3151-2008 mass flow transducers</li> <li>• MI 3272 flow meter transducers</li> </ul>	
<b>Calculation methods</b>	<p>Density: R 50.2.076-2010 "State standards on oil and oil products density. Calculation methods. Program and adjustment table."  Oil volume: State standard GOST R 8.595-2004 "Oil and oil products mass. General requirements for calculation methods."  Oil mass: State standard GOST R 8.595-2004 "Oil and oil products mass. General requirements for calculation methods."</p>	

# Control Systems for Oil Pumping Stations and Tank Farms



Programmable logic controllers (PLCs) for oil pumping stations and for tank farms are required to support of large number of I/O channels and reliable operation. All the while supporting hot-standby redundancy and hot-swappable modules for fast and convenient maintenance. Control systems put into operation for these applications, with the use of REGUL RX00 controllers, satisfy in full those requirements.

The I/O channel capacity for these systems often yields 3,000 and more channels. Each RTU cabinet houses two or three racks with I/O modules. The internal bus between racks utilizes connection over twisted pair cables while between the cabinets are used twisted pair or fiberoptic links. The architecture of the REGUL PLCs allows swapping RJ45 bus extension modules with fiberoptic modules and using off-the-shelf cables and connectors.

The REGUL solution has a standard 3-level structure:

**The upper level** of the system consists of an HMI or operator workstation, server hardware, and SCADA system with support of Modbus TCP, OPC DA/UA, and/or IEC 60870-5-104 protocol.

**The middle level** contains a central controller cabinet with redundant CPU racks, communications modules, communication controllers (if necessary), and remote terminal unit (RTU) cabinets. The PLCs used at this level are usually of the Regul R600 or R500 series, supporting in full various options of redundancy.

**The lower level** is represented by sensors and actuators in the configuration specific to each project.

## Data collection

- Collection of signals from analog, digital, intelligent transducers, and from process parameter sensors at the lower level of the control system
- Display of necessary information about process and equipment status
- Management of visual and sound alarms
- Generation of trends of process parameters
- Archiving of the process parameters, events, and actions of the operators and supervisors

## Monitoring and control

- Status monitoring and control of process equipment from operator rooms and from local, regional, territorial, and central control centers
- Automatic control of process parameters in accordance with preselected control criteria
- Communication with other systems and equipment in a facility
- Automatic, remote, and manual control of process equipment and actuators

## Handling of emergency situations

- Automatic protection and control interlocking of process equipment
- Identification of emergencies and of divergences of the process from preset modes
- Automatic engagement of backup equipment according to predefined algorithms

## Diagnostics

- Hardware and software self-diagnostics
- Diagnostics of the communication channels

## Security

- Protection against unauthorized access



### Structural Scheme: Remote I/O Redundant Ring-Type Network

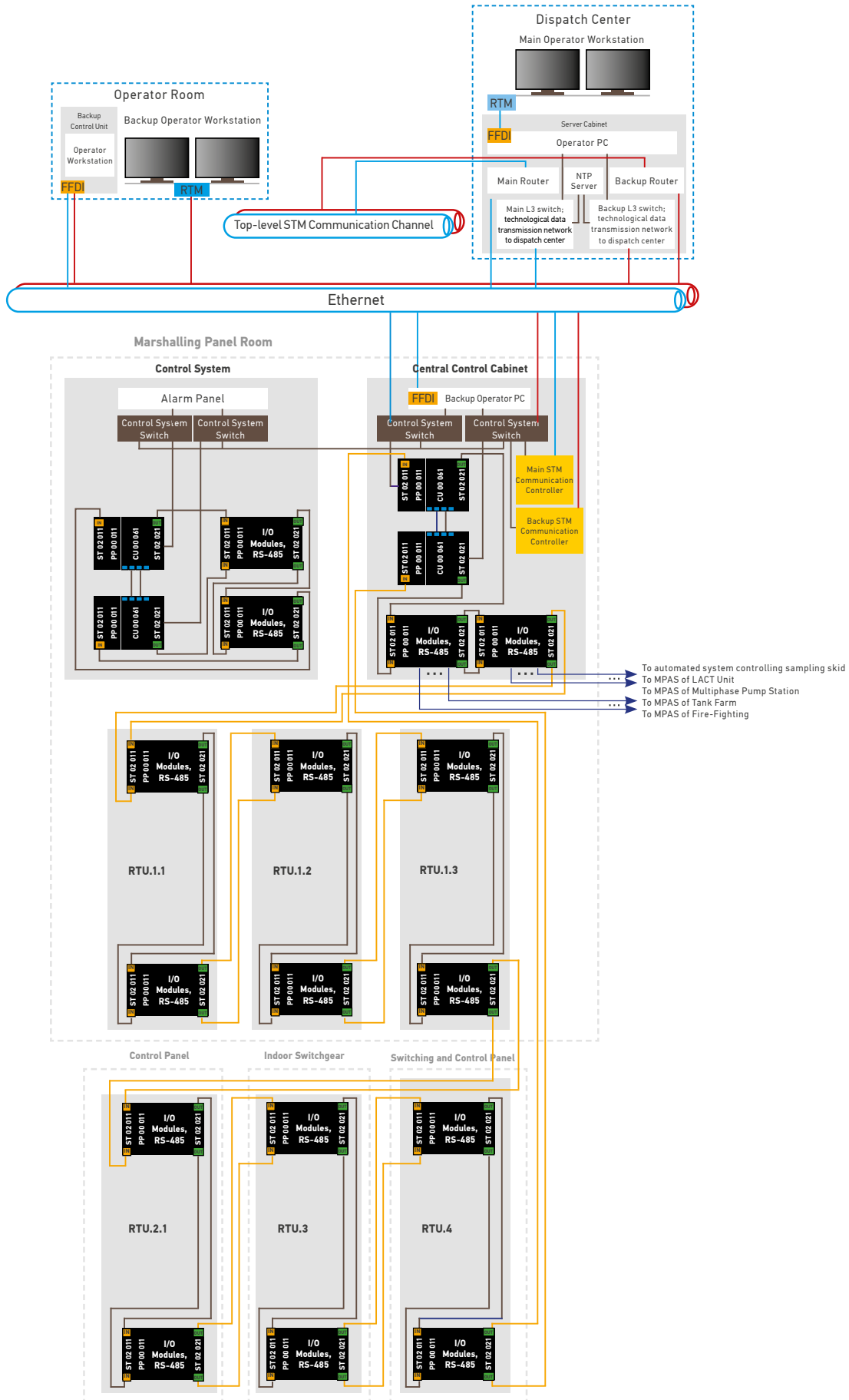

# Fire and Gas Control System



Another example of a distributed system based on the architecture similar to that of an oil pumping station's control system, is Fire and Gas Control System. This system is used in oil and gas production and in transport and storage facilities to configure fire alarm and fire-extinguishing systems of different types and complexities.

It is a flexible system with a variable set of components based on REGUL R500 and REGUL R600 programmable logic controllers with the support of redundancy and the hot-swapping of modules.

#### The system is designed to:

- Detect fire and unauthorized entry in protected areas, including indoor and outdoor installations at a risk of explosion
- Execute automatic remote control of water-cooling tank units and different types of fire-extinguishing systems including spray, water, foam, gas, powder, etc., both separately and in various combinations
- Send alarms and alerts to higher-hierarchy equipment such as operator workstations and to adjoining systems such as SCADA, automatic process control systems, central surveillance rooms, etc.
- Control, monitor, and protect technological equipment

#### System structure

---

HMI equipment (operator workstation) and a SCADA system supporting Modbus TCP, OPC, and IEC 60870-5-104 protocols

---

REGUL R500 programmable logic controller. Overall, this level includes:

- A central control cabinet, based on hot-standby CPU modules
  - Cabinets with I/O racks
  - Network for data transfer between the I/O racks, CPU racks, control center
  - An alarm panel cabinet
- 

Sensors, transducers, alarm announcers, light and sound alert, and actuators

---

#### Diagnostics

- Performs self-testing of software and hardware and automatic monitoring of the communication lines (for wired lines for breakdowns and short circuits, for fiberoptic and digital lines – for communication failures).
- Communication failures are detected on the lines:
  - With equipment that forms starting signal
  - With fire-extinguishing system devices (notifiers, alarm panels, electric valves, explosive cartridges, fire pumps, dosage pumps, fans, electric drives, etc.)

#### Redundancy and notifications

- Automatically switches power supply from the main line to backup line and vice versa, with a corresponding indication.
- There is an option of switching from automatic process control to remote (manual) and back.
- Notifications about fire event, signals of activating fire-extinguishing system and/or of tank water cooling are flexibly programmed as scenarios.

#### Control and monitoring

- Collects signals from security, fire and security, or fire notifiers. Addressing of the notifiers is done over the RS-485 interface with Modbus RTU protocol by connecting each notifier to a separate input in the system.
- Collects signals from the detection devices and other equipment impacting algorithm of operation (in case it is present in the system)
- Other equipment could be connected to the system over Ethernet or RS-485 interfaces (process control system, telemechanic devices, etc.)
- Collects electric signals from sensors monitoring functional state of the equipment (position, pressure, temperature, etc.)

## Notifications, visualizations, other

- Forms control signals for notification, evacuation, smoke and gas removal, etc.
- Priority logging and transmission into external systems notifications on fire, in respect to other signals are formed by the system
- Controls light and sound alarms
- Indication of activation of fire extinguishing system and/or tank water cooling, with indication of directions
- Access control
- Prevents unauthorized access to the system
- Visualization and archiving
- Displays all the required information, including status of the equipment
- Forms trend lines for the selected technological parameters
- Archives selected technological parameters, events, and actions of the operators

## Structural Scheme: RTU Redundant Ring-Type Network

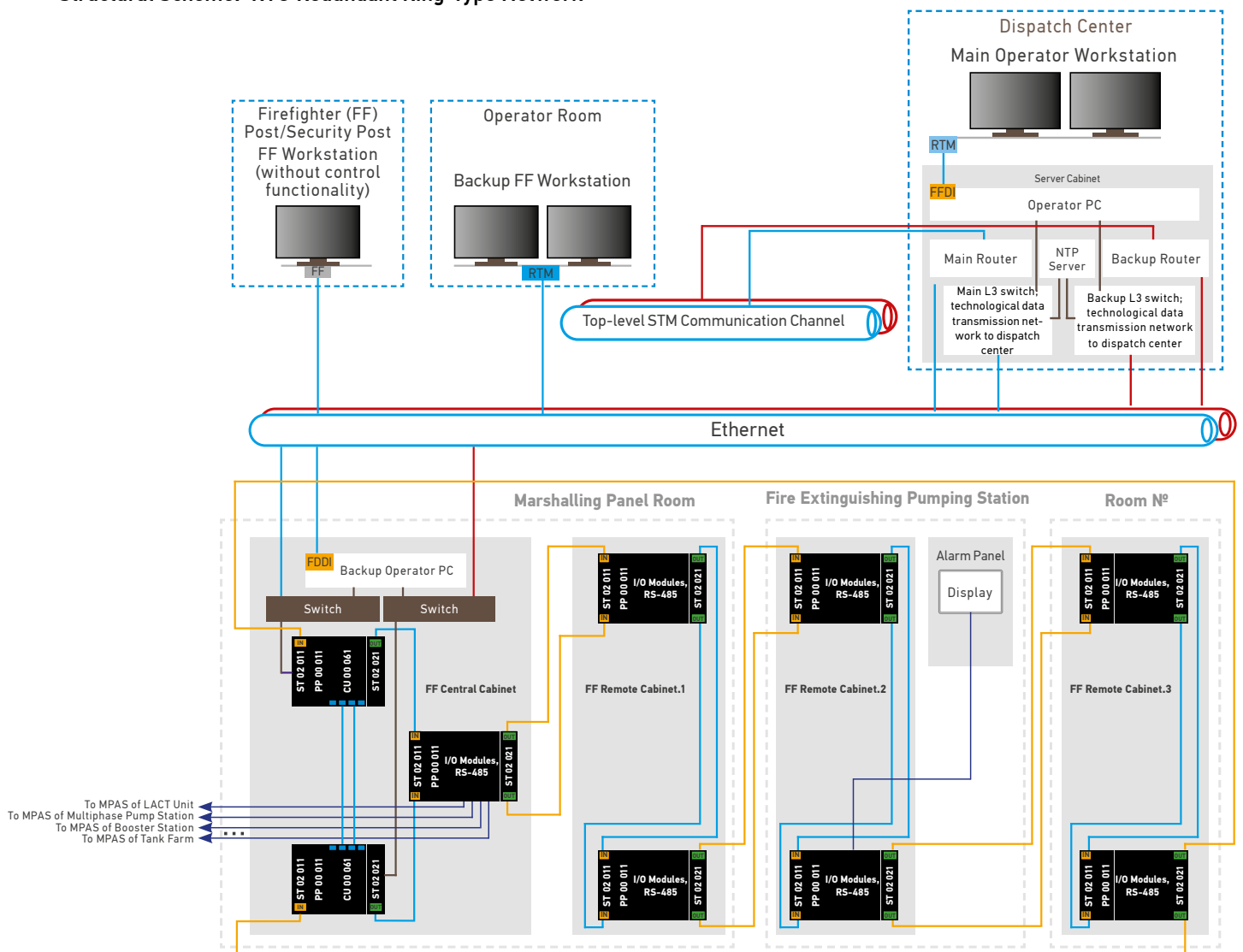

# Telemetry Solution



The built-in IEC 60870-5-101 and IEC 60870-5-104 telemetry protocols are a natural fit for creating a telemetry system for the oil and gas industry based on the REGUL RX00 controller.

The software/hardware telemetry solution is designed for use in the telemechanic systems that ensure centralized monitoring and remote control of linear long-distance oil pipeline equipment and other facilities related to oil and gas production and long-distance pipeline transportation.

In general, the telemechanics of the linear parts of long-distance pipelines has the following functions for each monitored site:

## Alerts

- Valve status and position
- Cleaning and diagnostic agent status
- Valve actuator failure and breakdown
- Line disconnection and switch status and position
- Presence of voltage in a transmission line along the route.
- Minimum and maximum control room temperatures
- Maximum level in the leakage accumulator at the scraper launcher-receiver
- Pressure-tap well flooding at trunk pipeline water barrier crossings.
- Scraper launcher-receiver flooding at trunk pipeline crossings of water barriers
- Leakage at scraper launcher-receiver at trunk line underwater passage
- In the absence of a separate transmission linear protection system and access control:
- Security alarm system status (control room, pressure takeoff wells).
- Fire alarm system in the control room.
- Perimeter surveillance alarm system at scraper launcher-receiver at trunk pipeline launcher-receiver.
- Alarm system of air escape valves located in the line valve unit.

## Control

- Line valves
- Command verification equipment (“control” and “unblock” commands)
- Security alarm system (security alarm “unblock” command)
- Circuit breakers and switches along transmission lines
- Security lighting

## Measurements:

- Actual pressure in the trunk pipeline
- Oil flow along the trunk pipeline
- Actual pressure in the disconnected backup lines in underwater passages
- Actual pressure in access chambers of passing, launching, and receiving of scraper outside pump station
- In the absence of a separate remote-controlled system of the cathode protection station:
- Electric current of the cathode protection station
- Voltage of the cathode protection station
- Protective “pipe-ground” potential
- Voltage at the electrochemical protection drainage point

## Teleregulation

- Actuator positions of the linear pipe control system
- Output voltage (current, protective voltage) of the electrochemical protection station

## Communication

- Send data necessary for the functioning of the leakage detection system (if required)
- Exchange data with the telemechanic equipment of the pump station, backup control center, and transit drain station via IEC 60870-5-101 and IEC 60870-5-104 telemechanic protocols



# EXAMPLES OF APPLICATIONS: POWER INDUSTRY

Automation in power industry includes a number of systems: turbine control, turbine protection, boiler, balance of plant. The capability of Regul RX00 PLCs and, in particular, Regul R600 PLC, to be fast and fault-tolerant, allows system integrators and power plant operators have only one line of controllers for all the systems.

A special stress in development of the controllers we put on the resistance to electromagnetic fields, often abundant in the power plants, and to the support of IEC 60870-5 protocols, namely IEC 101 and IEC 104.

Digital input modules have Sequence of Events capability built-in by default, to analyze events in the system step-by-step, without impact of the communication lines. Output modules can be configured for the strategies to properly shutdown the underlying system (s) in case of complete loss of communication.

Extension with the integrated AlfaRegul SCADA brings in redundant servers for operational control, trends, alarms, events, historical data, in-house developed noSQL database optimized for time series. Cascade regulation in the systems is available both at the controller level or through the centralized control from AlfaRegul.

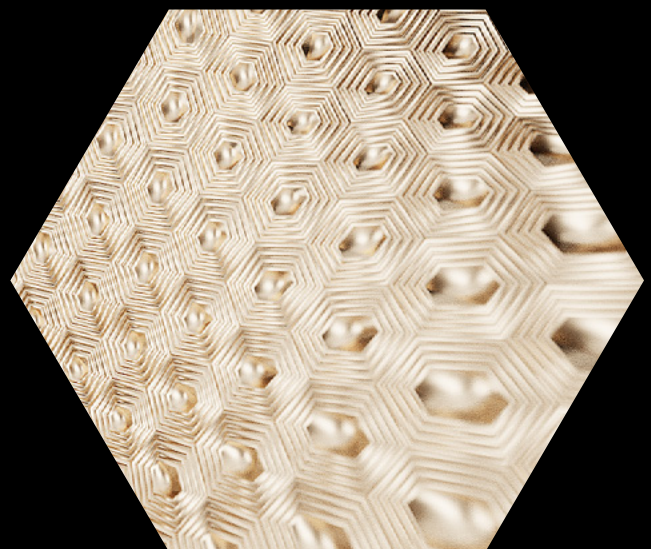

# Turbine and Auxiliary Equipment Control System

The system includes four subsystems with shared servers and workstations:

1. Governor control system. Redundant. Implements protection and control algorithms.
2. Condition monitoring system. Redundant. Load-carrying part of the system. Performs control of the positions of the turbine steam distribution regulating valves.
3. Auxiliary equipment control system. Non-redundant. Solves the tasks for automatic regulation and remote control of shut-off and control valves, and mechanisms of own purpose.
  - a. Grid water heater
  - b. Steam pipelines of the turbine
  - c. Oil system of a turbine unit
  - d. Turbine unit sealing system
  - e. Oil supply system for generator shaft seals
  - f. Cooling water system
  - g. Drainage system
4. Electronic overspeed trip (Triple Modular Redundant).
  - h. Grid water system
  - i. Condensate system
  - j. Oil purification and leakage collection system, etc.

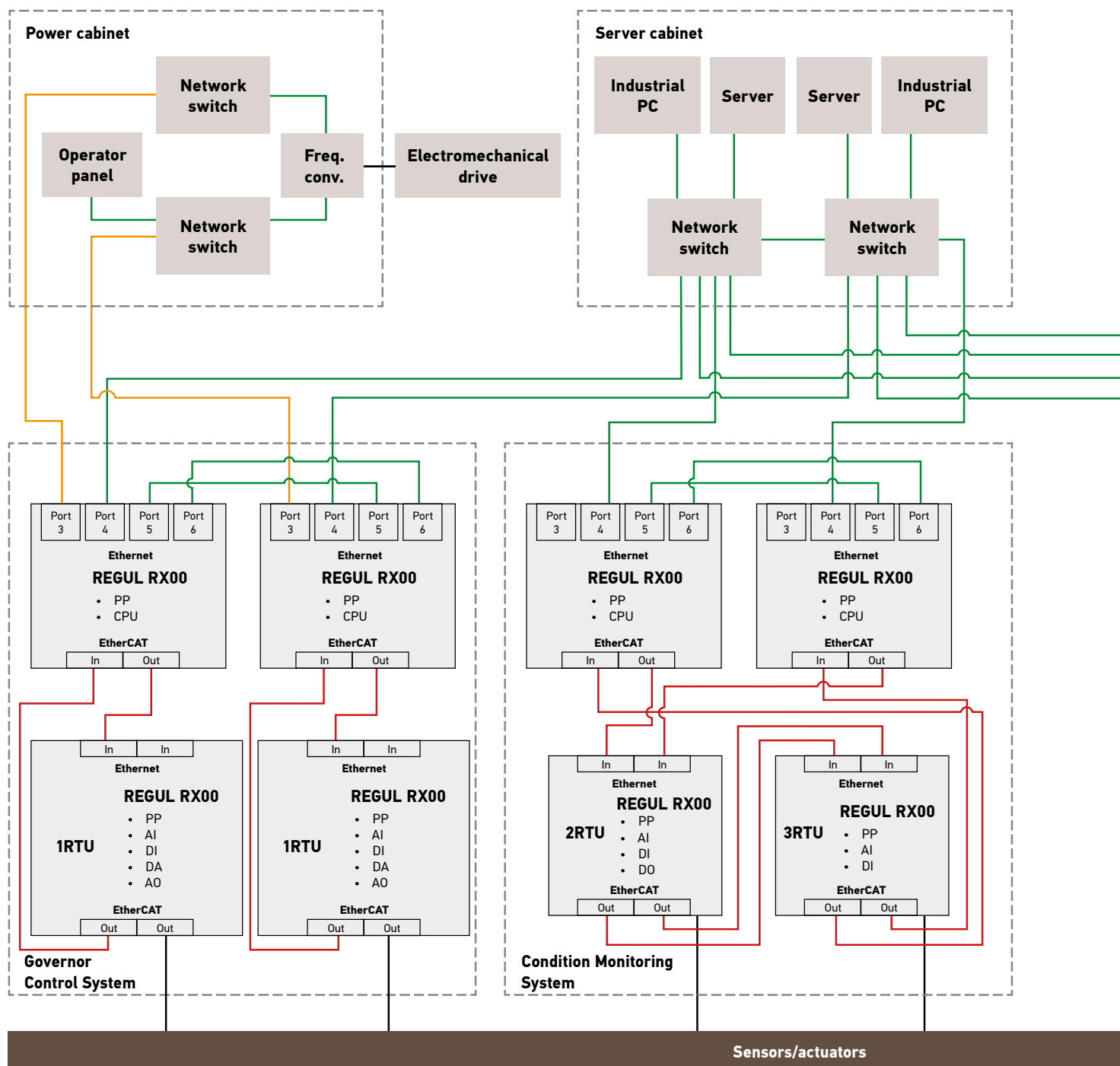

Upper level of the system has two or four operator workstations with equal permissions.

The workstations provide control of the equipment in real time. Local control panel is used to control regulating units and auxiliary mechanisms of the turbine and to check state of technological protections during maintenance operations on the equipment and during preparation for a launch.

Remote terminal units are installed into separate cabinets.

Control system's power supply subsystem provides power over a redundant line. The system can be extended in the future (there is spare capacity by I/O channels and by the CPU computing power).

- Ethernet (copper)
- Ethernet (fiberoptics)
- EtherCAT (fiberoptics)

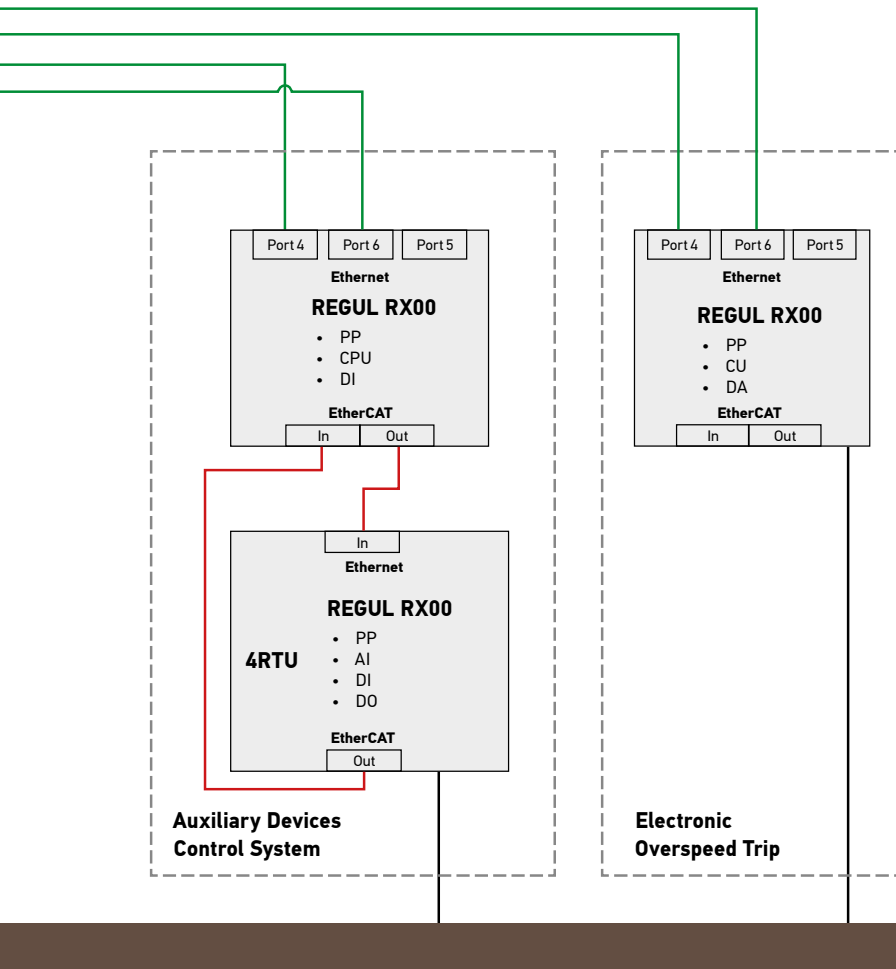

# Electric Part of the Turbine Control and Protection System



Rapidly and continuously changing technological processes in the turbines require reliable high-speed control systems with an emergency shutdown (ESD) function. For the implementation of this functionality in the upgrade of the existing control systems were selected Regul R600 and Regul R500 controllers.

The system was developed for the use with gas and steam turbines and was used retrofitting the existing control system. The system focuses on implementing maximum level of redundancy and tolerance to failures, delivering increased availability. Open approach and flexibility in extending allows implementation of other systems for the turbine with Regul controllers and use of only one software and one logic for the complete range of systems.

The system can automatically control a steam turbine in standard and emergency modes (of generation unit and of the power system), while monitoring load, live-steam pressure, positions of the control valves, signals from control devices at power unit/station/system.

Turbines that are currently in operation with this system vary from the small turbines for industrial applications to 800 MW turbine used in power generation. The system can be extended to provide participation of the turbine in primary and secondary frequency control

The redundancy is implemented at the levels of PLC, control, measurement equipment. And the solution provides timely diagnostics of the individual systems and control circuits of the actuators.

Implementation of the solution with the use of REGUL R600 (R500) PLCs allows a flexible configuration, connection to a remote SCADA (with support of the most common vendors on the market). Hot-standby operation of the CPU units and hot-swappable modules allow for a stable and continuous operation of the system.

## Protection

Implementation of the protection algorithm on the Regul controllers benefits from their increased fault tolerance and improves level of protection of your equipment while reducing frequency of maintenance.

- Turbine protection against an inappropriate reduction in steam pressure
- Activation of the control and shutoff valves in case of increased frequency and acceleration
- Turbine shutdown (via relay channel) without disconnecting the generator from the grid
- Short- and long-term emergency load release of the power unit, with restoring load by the signals from emergency automation. By the conditions for dynamic and static stability.
- Activation of the turbine's control valves when the electrical load has dropped
- Deep system diagnostics

## Control

High speed of operation of Regul controllers allows you to implement more efficient algorithms in operation and deliver higher performance of the turbine.

- Control of turbine rotation speed
- Steam pressure control, with alignment to the power system frequency
- Pressure control throttle (adjustment of live-steam pressure before the turbine)
- Sliding pressure operation (control mode with variable live-steam pressure)

At the core of the system are DA 03 011 / DA 03 021 counter modules that feature:

- Frequency measurement over three independent channels in two ranges (up to 10 kHz or up to 500 kHz)
- Provision of turbine overspeed protection via electronic overspeed trip firmware
- Verification of the protection state on a stopped turbine or during idling via built-in generator
- Receipt of signals from an incremental encoder (control of the actuator position)
- Receipt of signals from flow meter and control of the calibration settings

## System specifications

- 100% redundancy (including I/O modules)
- Generation of control actions in 10 ms
- Protection against issuing false control signals
- Archiving in 10-ms, 100-ms, and 1-s intervals
- Implementation of hot standby redundancy of control channels for 20 ms
- Hot-swapping of the PLC modules
- Heavy-duty operating conditions
- Mean time between failures of at least 100,000 hours

# Automatic Load-Frequency Control System



The Automatic Load-Frequency Control (ALFC) system regulates active power and frequency of the power units under its control to take part in the secondary (sometimes tertiary) frequency regulation. The system ensures that the group of automated power stations (power units) provides optimal frequency, according to the requirements and situation of the grid.

The system receives control signals from the centralized system for automatic power and frequency control and adjusts the load and frequency of the group. Operating parameters (secondary frequency regulation, rated primary frequency regulation, sustained turbine fast-valving signals) are communicated to the servers from the REGUL R600 PLC via ARTI3 protocol. Diagnostic information from the switches is communicated via the SNMP protocol.

The system is made as a cabinet with programmable logic controllers, servers, commutators, and HMI panel.

## System Components

- 2 x REGUL R600 programmable logic controllers in hot-standby configuration:
  - 24 VDC power supply module
  - R600 CU 00 061 central processor unit
  - Communication processor module with 4 x RS-485 ports with Modbus RTU and IEC 60870-5-101
  - Digital input module, 32-channel, 24 VDC with group galvanic isolation
- HMI panel in the cabinet door
- 2 x servers (main and backup; fan-free)
- 2 x commutators (main and backup)
- Power supply, protection, and lighting and cooling equipment

## Communications

- Simultaneous cyclic two-way data exchange between power units and ALFC system over RS-485 in Modbus RTU protocol, with the speed of at least 9,600 bit/s
- Simultaneous cyclic two-way data exchange between ALFC system and central system for automatic power and frequency control over IEC 60870-5-104 protocol
- Communication cycle of less than 1 s between the automatic power control systems of the power units and centralized system for automatic power and frequency control
- Transmission of the data on load-frequency control and rated primary frequency regulation to the plant's SCADA system

## Clock Synchronization

- All measurements and signals from remote units are bound to the astronomical time with error of maximum 100 ms
- Internal clock of the system is synchronized with the astronomical clock via an NTP server in the power plant's network

## Redundancy

- CPU modules of the PLC operate in hot-standby mode with redundant synchronization channel
- Archiving servers are redundant with automatic data synchronization
- Constant self-diagnostics and generation of alerts
- The system constantly monitors status of the communication channels with the central system and with the power units control systems, logs errors, forms corresponding signals
- Automatic selection of a functioning communication channel in case of restored operation
- Suspension of data transfer between the power units and centralized system in case of failure of both channels in one direction

## Turbine Control

- The PLC in the system runs algorithms for the automatic load-frequency control and for the turbine sustained fast-valving
- Signals from the emergency control system for fast-valving are received via "dry contact" (voltage-free) connection

## Data Archiving

- Archiving of data on changes in the time to collect parameters for automatic load-frequency control, rated primary frequency regulation, turbine sustained fast-valving
- Archiving of the events on appearing and disappearing of inaccurate data
- Archiving of the events on system operation, including modification of the tools and software
- All the archived data is stored for at least 3 months

## Monitoring and Reporting

- Included HMI visualizes operation of the system functions in form of tables, charts, reports
- The system can provide reports on the hardware and software state of the components
- Automatic or ad-hoc generation of the text files in the approved format with the changes in rated primary frequency regulation with 1 second steps
- Transfer of the archived files to the dispatch office over main or backup communication channel via FTP protocol

### Structural Scheme Automatic Load-Frequency Control System

- Twisted pair Ethernet Cat 5E (load and frequency control channel)
- Twisted pair Ethernet Cat 5E (rated primary frequency control channel)
- Twisted pair Ethernet Cat 5E
- Twisted pair RS-485 (Modbus RTU)
- Physical communication lines (dry contacts)
- Fiberoptical line, Ethernet

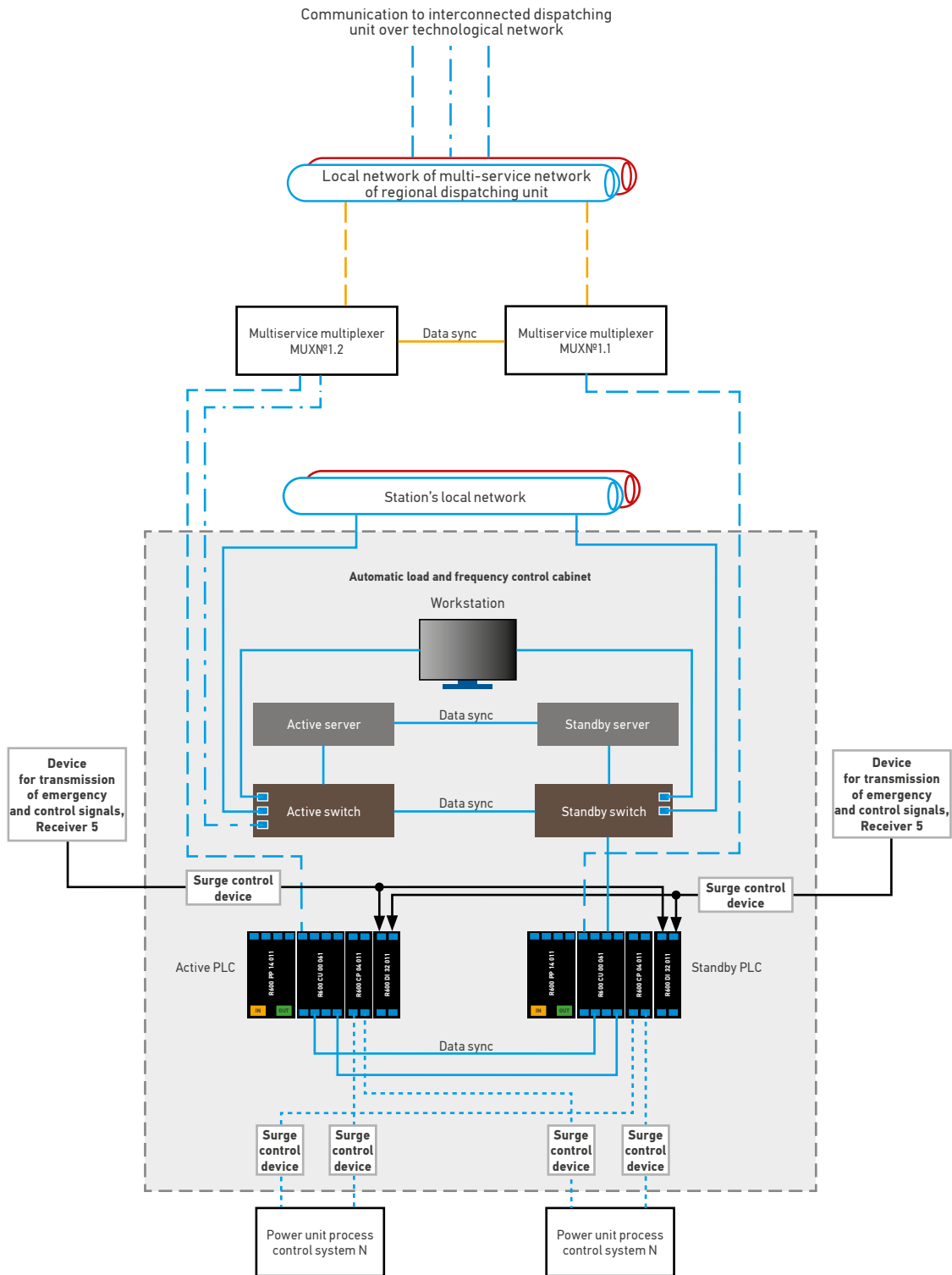



# Turbo Generator Vibration Monitoring System



Monitoring turbo-generators for state of vibration and mechanical parameters and providing timely diagnostics with notification of the operators are important for anticipating failures of the units and improving stability of their operation.

The system, developed by the engineers of the group, connects to the sensors of mechanical parameters via secondary converters. The converters send output signals of instantaneous values and unified 4...20 mA signals.

Signals with instantaneous values connect to the system's computer with the multi-channel ADC and Vibration Monitoring software that calculates and charts data for the diagnostics of:

- Harmonic parts of the vibration
- Rotating parts of the vibration
- Low-frequency vibration
- High-frequency vibration
- Surges of values of parameters
- Coefficient of vibration amplitude

Unified outputs of the converters are connected to a REGUL controller. In the controller are implemented all the protection and blocking algorithms, comparison of parameters with setpoints and notification on the overruns, forming of relay signals to an alarm and protection system.

To provide the required availability of the system are used two CPU modules of REGUL controller, redundant bus connections, redundant power supplies, and signals in the protection part are connected to different I/O modules.

A touch panel is installed in the cabinet for the configuration of setpoints, setup, masking, calibration of the channels, and for visualization of the selected parameters.

## Functional scheme of Turbo-generator Vibration Monitoring System

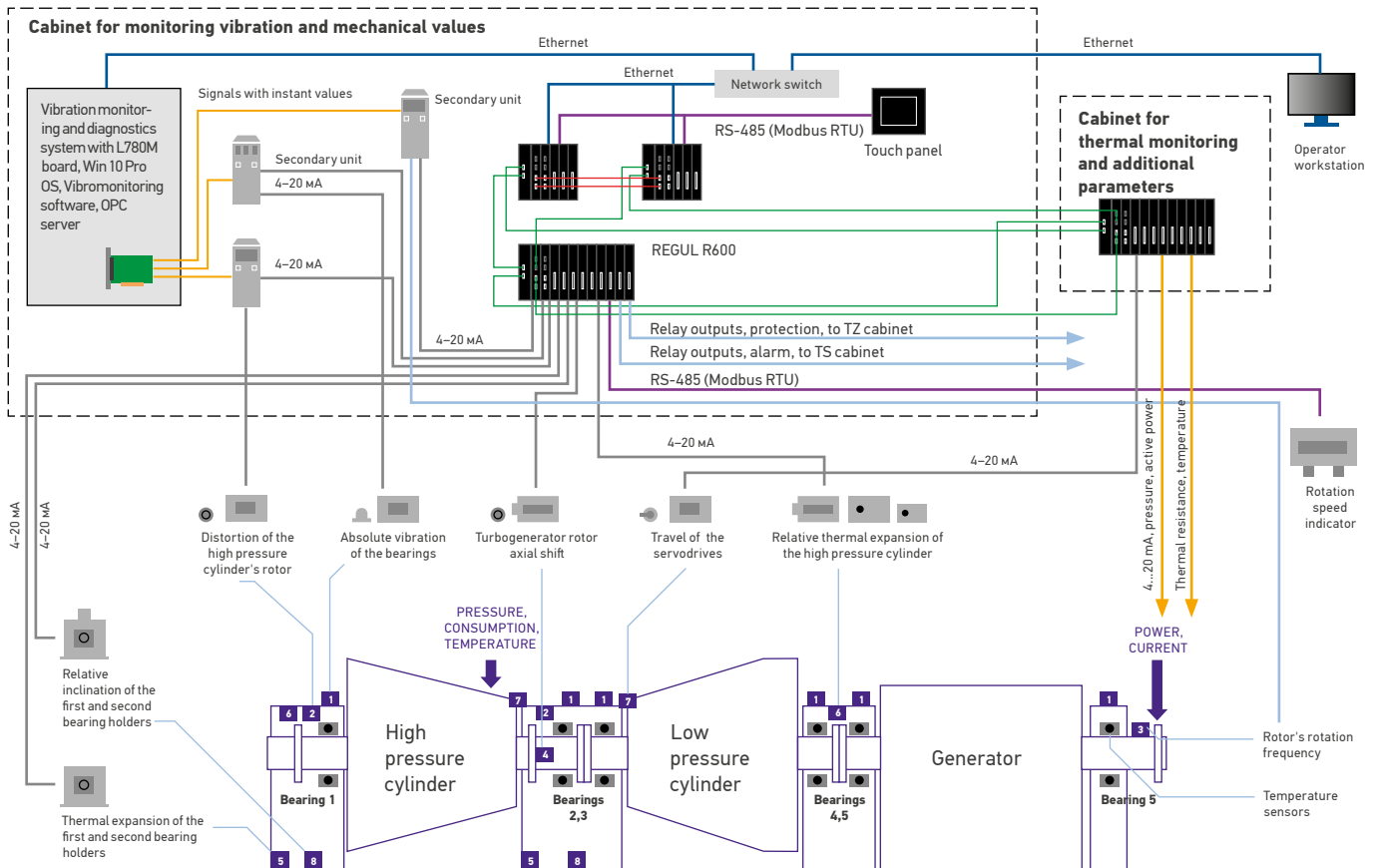

# Two-Axle Gas Turbine Control System

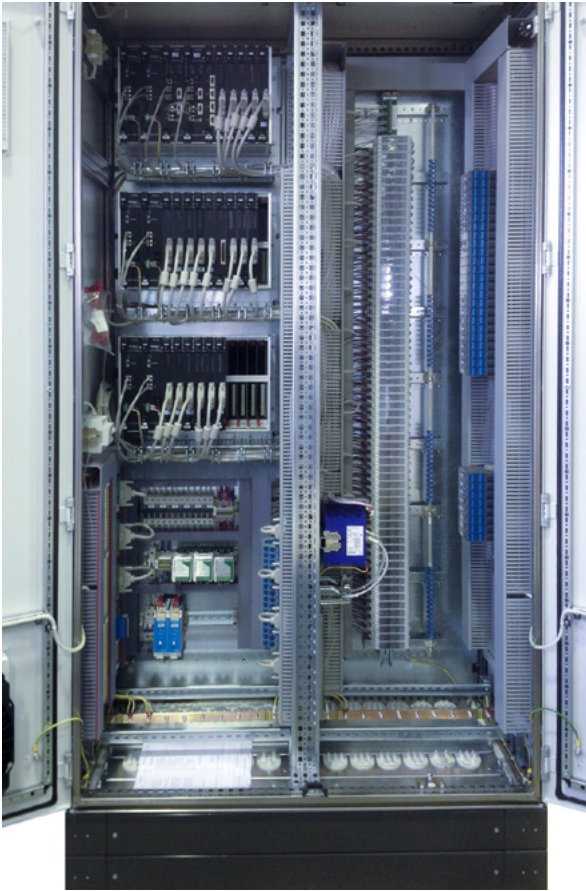

This gas turbine control system was developed on the base of REGUL R600 PLC. There are 3 racks with redundant power supplies. All the signals used in the turbine technological protections are connected to different modules, installed into different racks to exclude failure for a common cause.

## Features

- The system monitors technological parameters of the turbine and controls valves for fuel and air supply, exhaust gases, and direction of distributor.
- Application cycle time – 20 ms.
- All signals, used in the emergency shutdown systems of the turbine, were connected to separate modules, installed into separate racks, to exclude failure for a common cause.
- The MS5002E turbine used in this case has two axles. Operating frequencies of the axle rotation - 6000 and 7000 RPM. Due to this, there are 2 turbine rotation/power regulators and two overspeed trips. For this were installed 6 frequency sensors on the turbine (three on each axle).
- Frequency counters were connected to DA 03 021 modules of REGUL R600. These modules measure frequency over 3 channels for the regulation functions and have built-in overspeed protection.

# Boiler Control System

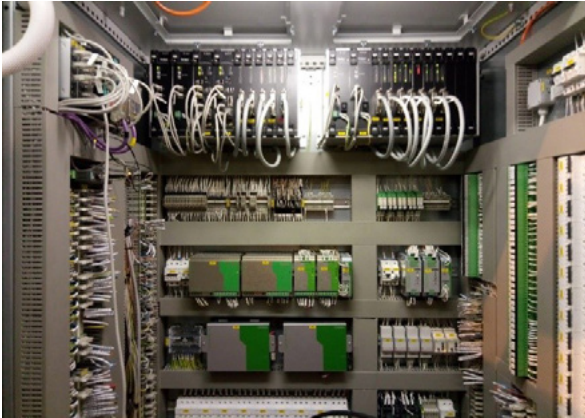

The control system was developed with the use of Regul R600 PLC with duplicate (mirror) redundancy

The system was designed to control boiler in all the range of operations (filling, burning, change of fuel from natural gas to fuel oil, shutdown) and control in case of emergency situations with implementation of emergency shutdown procedures.

The system provides group logical control of the executive mechanisms of the boiler. The mechanisms can be connected via physical or code lines: natural gas, fuel oil, and air, with steam and water pipelines. Each mechanism can operate in two modes – Automatic or Manual. In the Manual mode the mechanisms are controller from operator workstation or from the HMI on the control cabinet.

Regulators: fuel (natural gas), fuel-air, negative pressure, level in the boiler's drum

## Boiler protections

- Reduction / increase of the gas pressure before burner
- Reduction of the fuel oil before nozzle
- Reduction of negative pressure in the furnace
- Reduction of air pressure before burner
- Reduction / increase of water level in the drum
- Increase of steam pressure in the boiler's drum
- Burner flame going out
- Failure in power supply to the protection circuits
- Leak in gas unit

## Locks

- Automatic lock / opening of electromagnetic valve NO while opening/closing shutoff valve 1
- Lock of opening electromagnetic valve before ignition device and shutoff valves 1 and 2 before finishing unit pressure test
- Lock of opening shutoff valve 2 when flame is not on, or the butterfly is open
- Lock of opening shutoff valve 1 when shutoff valve 2 is open
- Lock of opening pressure test electromagnetic valve when shutoff valve 2 is open
- Lock to start burner without furnace ventilation and without gas unit pressure test (when fueled with natural gas)

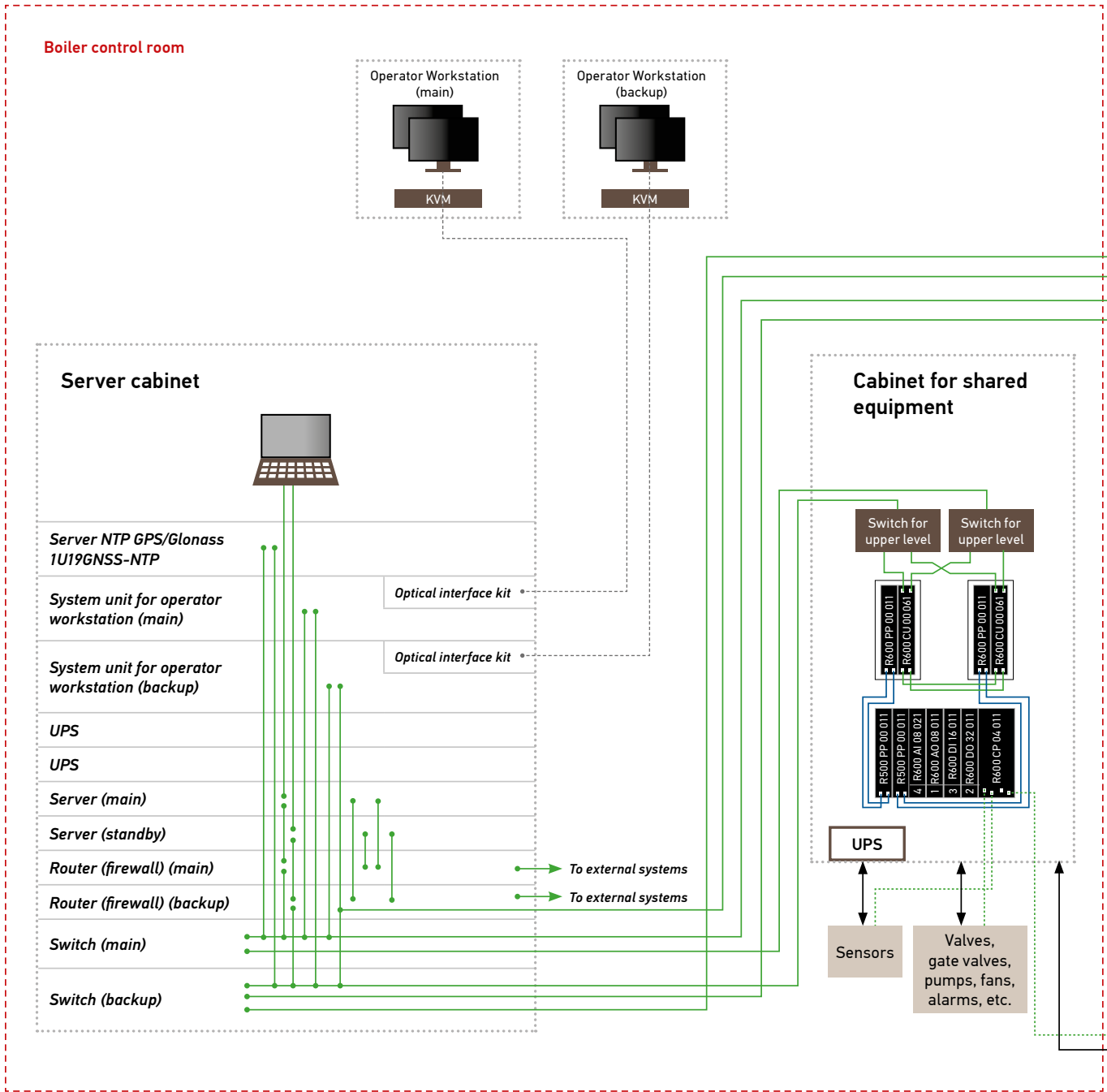

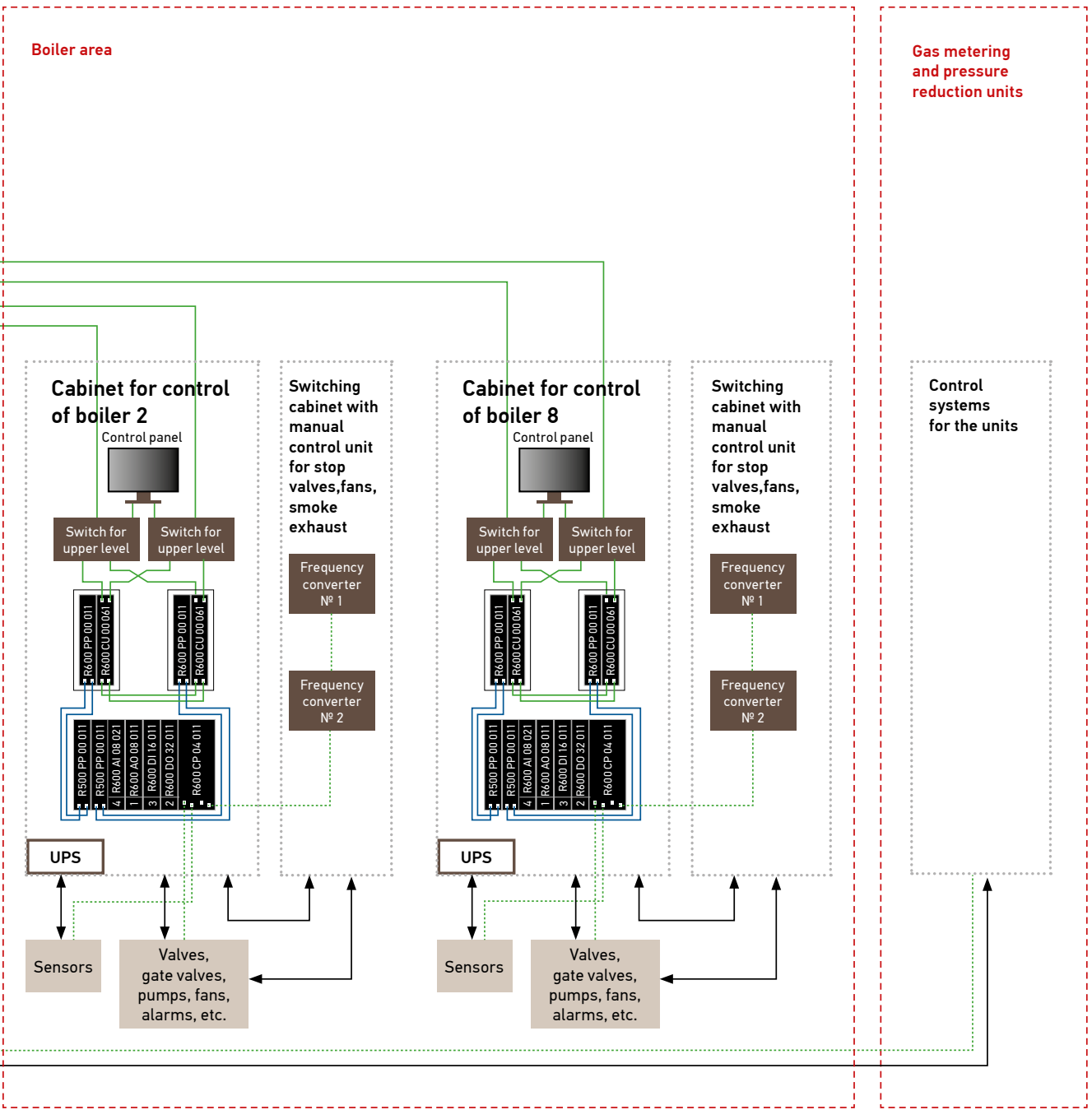





# SOLUTIONS

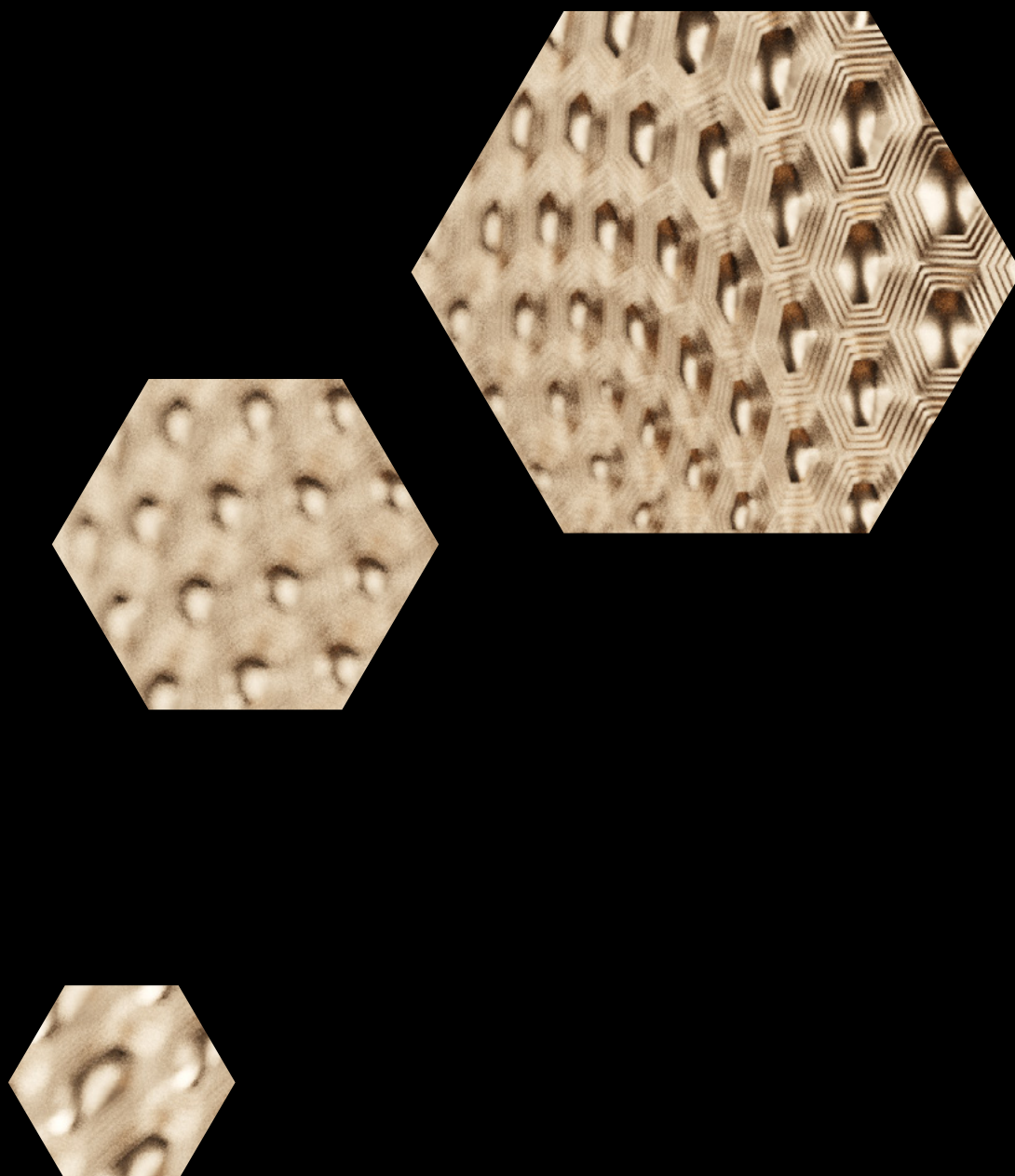

# Control System for Gas Pressure Regulators



The control system for gas pressure regulators is designed to ensure automatic control of the gas supply to the customer. The system provides flexible process automation and real-time control of the major technological parameters. It implements various scenarios involving the major equipment functions.

## Structure

The control system for gas pressure regulators is based on the REGUL R400 programmable logic controller and the R200 I/O modules. Connections to the measurement equipment and actuators are protected with the intrinsic safety barriers.

The REGUL R400 is an HMI for the operator to configure the system and parameters of the process and then monitor technological information, display events and access event logs. Information from the system can be sent to external systems via digital interfaces, like RS-485 or Ethernet.

The system constantly monitors:

- Input pressure
- Output pressure
- Gas flow

The data collected then passes through a specially developed algorithm to deliver constant flow of the gas with the required parameters.

The system can operate with one line, two lines, or two lines in parallel with identical configuration to provide redundant operation.

## Features

- Supports custom configurations
- Displays operational data on the local HMI
- Supports integration with SCADA systems (via Modbus TCP, OPC DA/UA, IEC 104) for data collection, trending, remote monitoring of operation
- Configurable locally or remotely from Epsilon LD software
- Supports access via web to the HMI panel in REGUL R400
- Can be supplied with a GSM modem for data transmission

## Optional configurations

- Pulse reading from meter
- Pulse reading from flow computer
- Operation with two lines in parallel

## Major functions

- Remote control of the natural gas pressure and flow at gas distribution stations
- Automatic control of the natural gas pressure and flow in accordance with a pre-set scenario
- Status monitoring and equipment checks
- Gas supply optimization and energy efficiency improvement (due to the keeping of the preset natural gas flow to smoothen down peak loads and the use of the gas transport system as a gas storage facility)
- Prevention of gas flow exceeding the gas meter range (gas meter overload protection)
- Safety valve duplication (control of the pressure sensor activation signal)
- Management of multi-thread systems with shock-free thread activation/deactivation and a uniform load distribution among the threads

Control system for gas pressure regulators can also be extended with an add-on to cover the functionality of a gas distribution station.

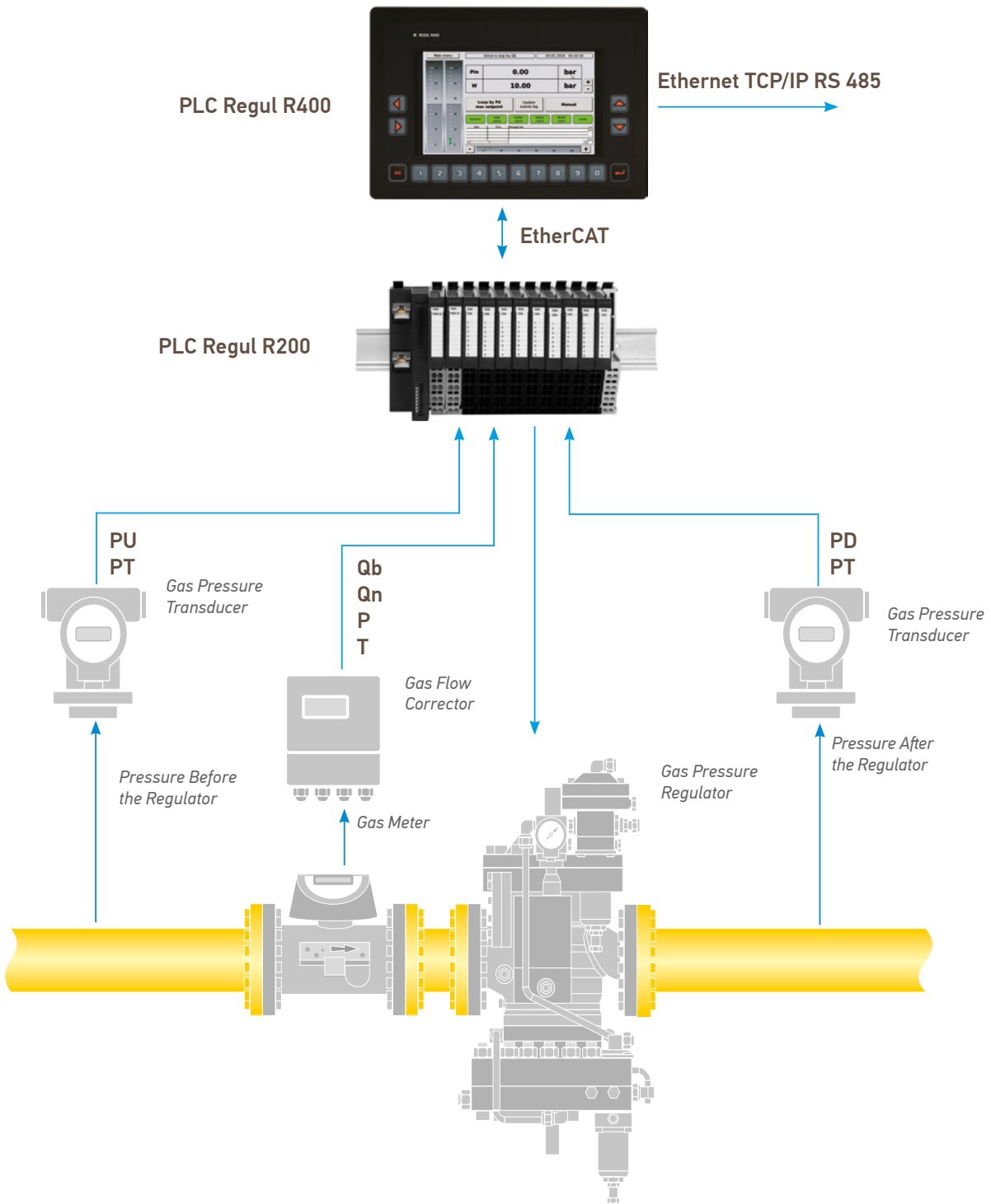

# Gas Odorizing Unit Control System



The odorizing unit control system was designed to automatically control the process of supplying odorant to a gas pipeline in proportion to the actual natural gas flow with a given degree of odorizing

## Structure

The odorizing unit control system is based on the REGUL R400 programmable logic controller and the REGUL R200 I/O modules. Alternatively, the system can be equipped with a third-party HMI panel with Modbus TCP connection. Connections to the measurement equipment and actuators are protected with the intrinsic safety barriers.

The REGUL R400 is an HMI for the operator to configure the system and parameters of the process and then monitor technological information, display events and access event logs. Information from the system can be sent to external systems via digital interfaces, like RS-485 or Ethernet. Support of printers and keyboard by the R400 controllers and external monitors via DVI port allow for creation of a complete workstation.

## Features

- Supports two dosing pumps in hot-standby configuration
- Uses a flow meter (Coriolis or positive displacement type) for a closed loop (feedback) control
- Displays operational data on the local HMI
- Supports integration with SCADA systems (via Modbus TCP, OPC DA/UA, IEC 104) for data collection, trending, remote monitoring of operation
- Configurable locally or remotely from SCADA
- Can be supplied with a GSM modem for data transmission

## Major Functions

- Monitors level of the odorant in the supply tank
- Monitors pressure of gas in the supply
- Supplies odorant at a required concentration in proportion to the gas flow
- Logs events and breakdowns
- Generates reports
- Supports external printers for printing reports
- Transfers information to SCADA
- Supports data storage to an external USB flash drive
- Controls access according to the user permissions

### Structure of the Gas Odorizing Unit Control System

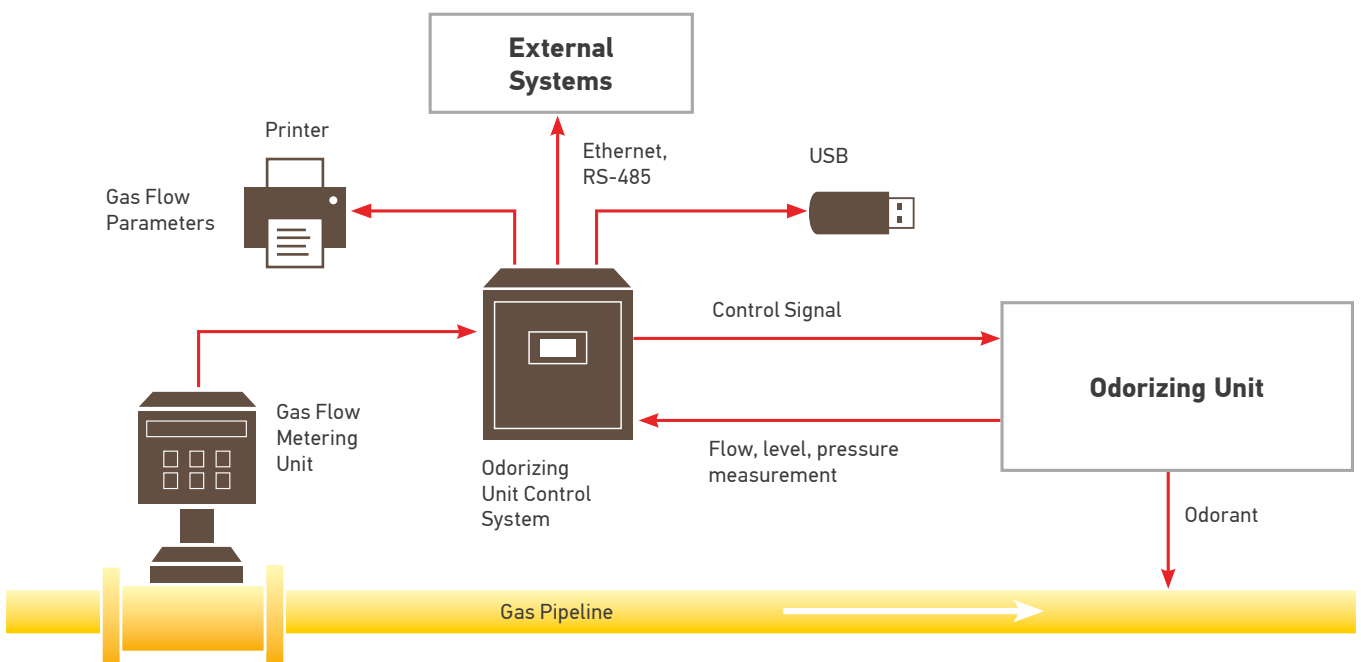

# Electronic Overspeed Trip for Steam and Gas Turbines



Turbine overspeed protection is one of the critical areas in turbine control, and electronic trip systems can come useful, especially when the rotation speed is at 10000 rpm or more. The system was designed as an electronic overspeed trip that can be used on new turbines or could be retrofitted into an already installed system. The range of turbines covered is from small industrial to large power industry turbines.

The system measures the rotation frequency and compares it with an emergency setpoint. When a critical speed is reached, the system sends a digital signal to stop the turbine while taking into account its acceleration. That is, if there is acceleration, the recalculates and reduces setpoint so that the rpms don't overshoot the critical value.

## Equipment configuration

The system is Triple Redundant (TMR) and is built around frequency measurement DA 03 021 custom-designed module with integrated software and frequency generator. The system has three of these modules, and each is connected to one or two frequency sensors.

The power is supplied to the modules and sensors from separate external power sources. Digital signals are joined together in the external majority circuit according to 2-out-of-3 principle.

To perform safety checks when the turbine is shut down, the system switches from sensor input to the frequency generator, built into the DA 03 module. The generator provides a set frequency to the measurement circuit, taking into consideration acceleration.

The CPU module in this systems serves, only to perform diagnostics and to generate tasks for the tests.

## EAB-REGUL

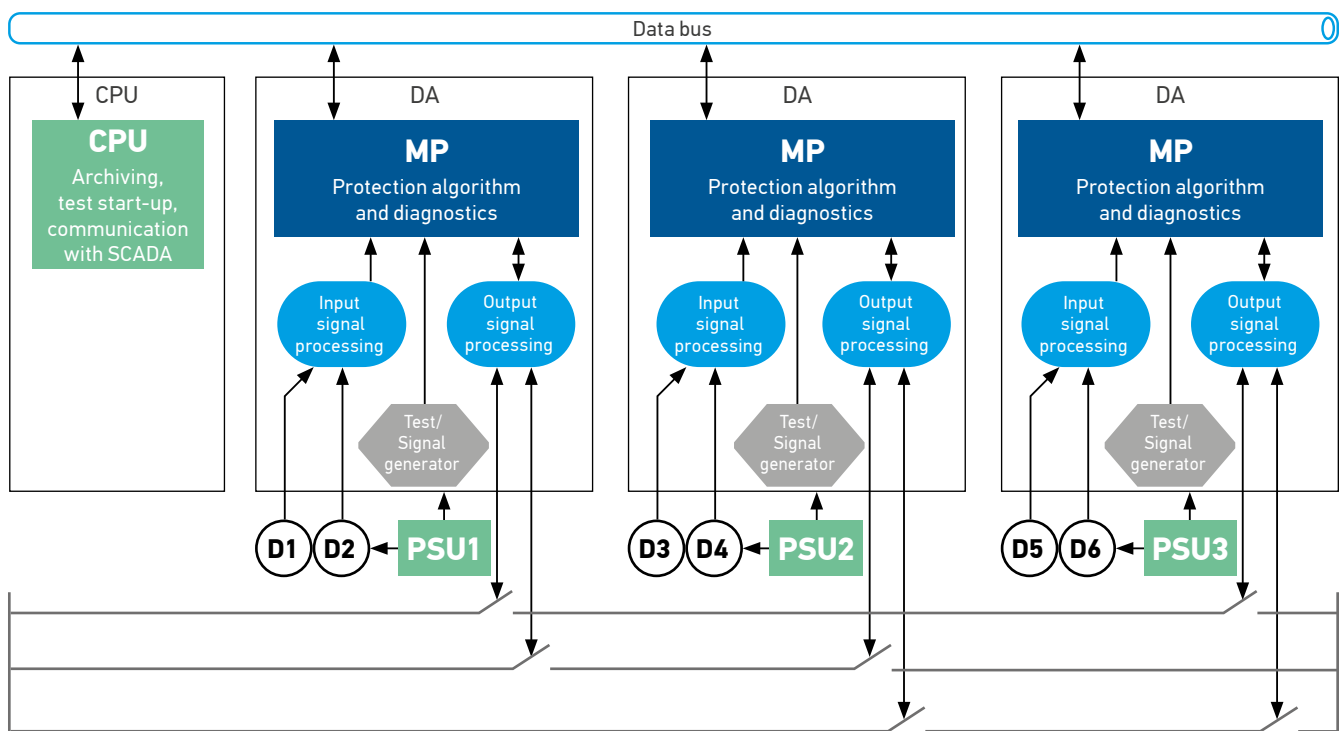

# Industrial Converter Gateway

The converter gateway was implemented with Regul R200 controllers and receives data via various protocols, converts it into its proprietary format, and sends data to use by another protocol. This approach provides no direct connection between the networks and allows to divide them, increasing the security level in the system.

**Communication gateway converter is designed to:**

- Receive data via OPC DA 2.0/3.0, OPC UA, and IEC 60870-5-104/IEC 60870-5-101 protocols
- Convert the received data and transfer it via IEC 60870-5-104/IEC 60870-5-101 and Modbus RTU/Modbus TCP protocols

## Features

- 1 x RS-232 interface (exchange protocol: Modbus RTU or IEC 60870-5-101)
- 1 x RS-485 interface (exchange protocol: Modbus RTU or IEC 60870-5-101)
- 2 x RJ45 Ethernet interface (exchange protocols: OPC DA 2.0/3.0, OPC UA, IEC 60870-5-104)
- Maximum speed of float-type parameter transfer via Modbus RTU protocol is 1,000 parameters/s
- Maximum speed of float-type parameter transfer via IEC 60870-5-101 protocol is above 1,000 parameters/s depending on the frequency of the data status changes

For the power generation and distribution, the function of the gateway converter is performed by the automatic load-frequency control system.



REGUL RX00  
PLC SERIES

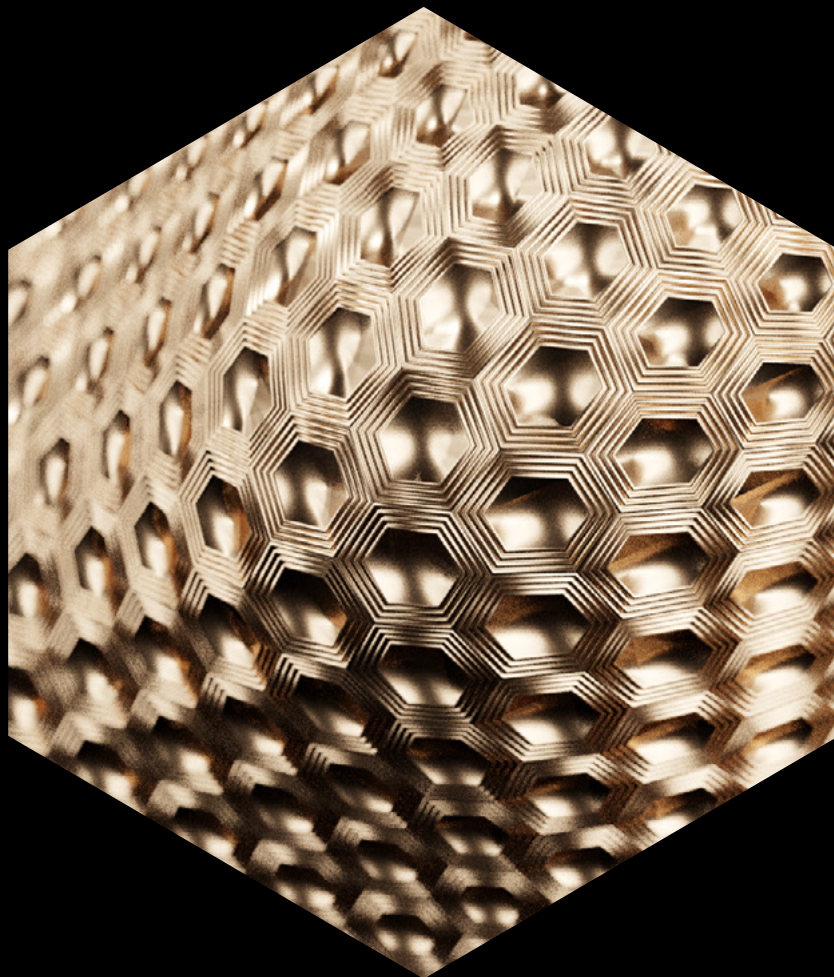
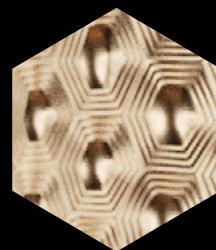

# REGUL R600 Programmable Logic Controller



Regul R600 is a fault-tolerant real-time programmable logic controller, designed for the use in process industries, where additional electromagnetic protection, vandal-proof housing, and/or extended temperature range are preferred.

<p><b>Applications</b></p>	<ul style="list-style-type: none"> <li>• Fault-tolerant process control systems for             <ul style="list-style-type: none"> <li>– Steam and gas turbines (control and emergency protection)</li> <li>– Oil pumping stations and gas compressors</li> <li>– Main and auxiliary systems at power stations</li> <li>– Fire and gas systems</li> <li>– Water management systems</li> </ul> </li> <li>• Fiscal applications (for example, LACT units)</li> <li>• Applications with unstable connection to SCADA</li> <li>• Applications with large number of tags sent to SCADA</li> </ul>
<p><b>Redundancy</b></p>	<ul style="list-style-type: none"> <li>• Hot swapping of all modules</li> <li>• Hot-standby CPU modules</li> <li>• Dual ring high-speed internal data bus</li> <li>• Automatic power distribution between power supply modules</li> <li>• Redundancy of CPU, CPU interconnection, I/O modules, power supply modules, SCADA connection</li> <li>• Hybrid counter/digital modules with support of 2oo3 voting at the level of modules</li> </ul>
<p><b>Features</b></p>	<p>General</p> <ul style="list-style-type: none"> <li>• Real-time programmable logic controller</li> <li>• Modular configuration, allowing flexible extension and change of configuration</li> <li>• Supports up to 130,000 channels</li> <li>• Improved electromagnetic protection of the controller and enclosure of the modules, protective module form factor</li> <li>• In-module event archiving</li> </ul> <p>Processing power and redundancy</p> <ul style="list-style-type: none"> <li>• Minimum application cycle time – 1 ms (5 ms with redundancy)</li> <li>• Scan time – 1 ms</li> <li>• Switchover in 5 ms</li> <li>• Processing of complex algorithms with powerful CPU modules and built-in microprocessors in I/O modules</li> </ul> <p>System configuration</p> <ul style="list-style-type: none"> <li>• Up to 12 modules in a rack, up to 255 racks, up to 10 km (via fiberoptic line) between racks</li> <li>• RJ-45, SFP, or mixed connection between racks</li> <li>• Star, ring, or mixed network topologies</li> <li>• CPU module can be placed into any rack</li> </ul> <p>Programming and visualization</p> <ul style="list-style-type: none"> <li>• Programming in Epsilon LD software with IEC 61131-3 languages + CFC</li> <li>• Online application update</li> <li>• Remote configuration/maintenance and application updates</li> <li>• Special firmware with MySQL database server</li> <li>• CPU module with DVI output for connecting a display and using Target-visualization</li> <li>• Web visualization option in CPU modules</li> </ul>

<b>Communications</b>	Supported interfaces	
	<ul style="list-style-type: none"> <li>• RS-232 (9-pin, full duplex, speed 300–115, 200 bps, opto-isolation 500/1500 V, overvoltage protection)</li> <li>• RS-422/RS-485 (9-pin, speed 300–115, 200 bps, full-channel opto-isolation 500/1500 V, overvoltage protection) – up to 96 ports per controller</li> <li>• Ethernet 10/100/1000 RJ-45 (full duplex) – up to 4 ports per CPU</li> <li>• Ethernet 10/100/1000 fiberoptic (single-mode, multi-mode) – up to 2 ports per CPU</li> </ul>	
<b>Design</b>	Built-in communication protocols*	
	<ul style="list-style-type: none"> <li>• IEC 60870-5-101 (master/slave)</li> <li>• IEC 60870-5-104 (master/slave)</li> <li>• Modbus RTU (master/slave, with expansion capabilities)</li> <li>• Modbus TCP (master/slave, with expansion capabilities)</li> <li>• OPC DA, OPC UA</li> </ul>	
	*Additional communication protocols, including non-standard ones, can be implemented according to your requirements.	
<b>Specifications</b>	Minimum application cycle time	1 ms (5 ms in redundant configuration)
	Scan time	1 ms
	Switchover time from main to standby controller	From 5 ms (1-2 cycles)
	Timing accuracy	50 µs
	Processor	Intel Atom
	RAM	1 GB
	SSD	4 GB (optional up to 64 GB)
	Mean time between failures (MTBF) for a controller module	>150,000 hours
	Input power	<ul style="list-style-type: none"> <li>• 85...264 VAC</li> <li>• 18...36 VDC</li> <li>• 120...370 VDC</li> </ul>
	I/O module size (W x H x D)	30 x 267 x 186 mm
	Operating temperature range	– 40...+60°C
	Approvals	CE, EAC, GOST-R, FCC-ready

## Central Processor Unit (CPU) Modules

	CU 00 051	CU 00 061	CU 00 071
Redundant operation	Complete	Complete	Complete
Processor type	Intel Atom	Intel Atom	Intel Atom
RAM	1 GB	1 GB	1 GB
Flash memory	-	-	-
SSD	2 GB + 4 GB	2 GB + 4 GB	2 GB + 4 GB
Serial ports	1 x RS-232, 1 x RS-485	1 x RS-232, 1 x RS-485	1 x RS-232, 1 x RS-485
Network ports	4 x Ethernet RJ45	2 x Ethernet RJ45, 2 x Ethernet FO	2 x Ethernet RJ45, 2 x Ethernet FO
Integrated MySQL database	-	-	Yes
USB host	-	-	2 ports
DVI port	-	-	Yes
GPS / Glonass receiver	Yes	Yes	Yes
Approvals	CE, EAC, GOST-R, FCC-ready	CE, EAC, GOST-R, FCC-ready	CE, EAC, GOST-R, FCC-ready

All models with index (W) include a web server with support of Web visualization (prepared in Epsilon LD software)

## Analog Modules

	AI 16 011	AI 08 021	AI 08 031	AI 08 041	AO 08 011
Type	Analog Input	Analog Input	Analog Input	Analog Input	Analog Output
Number of channels	16	8	8	8	8
Current measuring range	<ul style="list-style-type: none"> <li>0...20 mA</li> <li>4...20 mA</li> </ul>	4...20 mA	-	<ul style="list-style-type: none"> <li>0...20 mA</li> <li>4...20 mA</li> </ul>	-
Voltage measuring range	-	-	-	<ul style="list-style-type: none"> <li>0...+10 V</li> <li>-10...+10 V</li> </ul>	-
Current output range	-	-	-	-	<ul style="list-style-type: none"> <li>0...20 mA</li> <li>4...20 mA</li> </ul>
Voltage output range	-	-	-	-	-
Thermocouples	-	-	R, S, B, J, T, E, K, N, A-1, A-2, A-3, L	-	-
Thermal resistances	-	-	Cu50, Cu100, Pt50, Pt100, Ni50, Ni100	-	-
Resolution (incl.overflow)	14 bits	16 bits	24 bits	16 bits	16 bits
Operating error	± 0.1%	± 0.1%	± 0.1%	± 0.025%	± 0.1%
ADC/DAC	Shared	Per channel	Shared	Per channel	Per channel
HART	-	Yes	-	-	-
Galvanic isolation	Common	Channel	Common	Channel	Channel

## Digital Modules

	DI 32 011	DO 32 011
Type	Digital Input	Digital Output
Number of channels	32 (4 groups x 8 channels)	
Voltage	24 VDC	24 VDC, 0.5 A
Galvanic isolation	Group	

## Communication Processor Modules

	CP 04 011
Ports	4
Interface	RS-485
Protocols	<ul style="list-style-type: none"> <li>Modbus RTU</li> <li>IEC 60870-5-101</li> </ul>

## Counter Modules

	DA 03 011	DA 03 021
Number of channels	<ul style="list-style-type: none"> <li>3 x Frequency</li> <li>6 x Digital Input</li> <li>6 x Digital Output</li> </ul>	<ul style="list-style-type: none"> <li>3 x Frequency</li> <li>6 x Digital Input</li> <li>6 x Digital Output</li> <li>1 x Frequency Generator</li> </ul>
Channel supply voltage	3, 5, 12, 24 V	5, 12, 24 V
Digital input, voltage	24 VDC	24 VDC
Digital output, voltage	24 VDC, 0.5A	24 VDC, 0.5A
Frequency measurement range	<ul style="list-style-type: none"> <li>1 Hz ... 500 kHz</li> <li>1 Hz ... 10 kHz</li> </ul>	<ul style="list-style-type: none"> <li>1 Hz ... 500 kHz</li> <li>1 Hz ... 10 kHz</li> </ul>
Pulse counting range	0 ... 2 <sup>64</sup>	0 ... 2 <sup>64</sup>
Operating error	± 0.01%	± 0.01%
Pulse-counting error	± 1 pulse	± 1 pulse
Galvanic isolation	Channel	Channel
Built-in firmware	<ul style="list-style-type: none"> <li>Frequency counter up to 10 kHz with pulse counter</li> <li>Frequency counter up to 500 kHz</li> <li>Data processing from encoder</li> <li>LACT unit</li> <li>Frequency counter up to 500 kHz</li> <li>Data processing from encoder</li> <li>LACT unit</li> </ul>	<ul style="list-style-type: none"> <li>Frequency counter up to 10 kHz with pulse counter</li> <li>Frequency counter up to 500 kHz</li> <li>Data processing from encoder</li> <li>LACT unit</li> <li>Frequency counter up to 500 kHz</li> <li>Data processing from encoder</li> <li>LACT unit</li> <li>Electronic overspeed trip</li> </ul>

## Power Supply/Bus Extension Modules

	PP 14 011	PP 14 021	PP 14 031	PP 14 041
Voltage	24 VDC	24 VDC	220 VAC/VDC	220 VAC/VDC
Power	75 W	75 W	75 W	75 W
Regul bus ports	2 x RJ-45 (IN, OUT)	2 x FO (IN, OUT)	2 x RJ-45 (IN, OUT)	2 x FO (IN, OUT)
Galvanic isolation	-	-	-	-

## Chassis/Cables

	CH 07 011	CH 14 011	OO 00 000	DB 37 020	PCL-10137-2E
Type	Chassis	Chassis	Empty module (slot cover)	Cable	Cable
Slots	7	14	1		
Connector type	-	-	-	1 x DSUB-37 (male)	2 x DSUB-37 (male)
Length	-	-	-	2	2

## Smart I/O Modules

Each input/output module in the REGUL R600 series holds two independent ports for communicating with CPU modules over Regul bus. This allows information to be delivered from modules simultaneously to active and standby CPU and provide instant switchover.

The primary processing of a signal is performed in the module and includes:

- Signal diagnostics for range overshooting and abrupt value changes
- De-jittering function for digital signals
- Programmable averaging time
- Signal conversion values in engineering units
- Monitoring for a short-circuit or open input circuit of analog signals
- Monitoring for an open output circuit of analog signals
- Configuration of output presets

Input/output modules provide for:

- Support for the redundant bus communication
- Maximum delay for generating an output signal when the input set point (input-output) is triggered: 5 ms
- Galvanic isolation between the internal and external circuits up to 1000 V
- Assignment of timestamps with an accuracy of 1 ms
- Transmission of diagnostic data and different statuses

## Redundancy

### Major features

- CPU modules operate in hot standby mode, with parallel execution of application
- Switchover is done in 1-2 cycles
- Dual ring bus tolerates several bus failures without loss of control
- I/O modules communicate with each of the CPU modules independently from their status
- Built-in protection from two masters in one system
- The system can tolerate multiple reasons of failures

### Conditions to transfer control

- Operator stopped application on the active CPU
- Operator requested a switchover from the configuration software
- An error was identified on the bus
- Communication to the active CPU was lost

### Optional configurations

- Dual sync connection between the CPUs provides additional layer of protection
- Multiple power supply modules (two or more) provide power even in most difficult situations
- Dual SCADA connection and large local data storage deliver redundancy of operation on an unstable communication channel
- I/O modules can be installed in a mirror/duplicate configuration for continuous operation in case of I/O failure

## REGUL R600 Redundancy Schemes

### 100% Mirror Redundancy

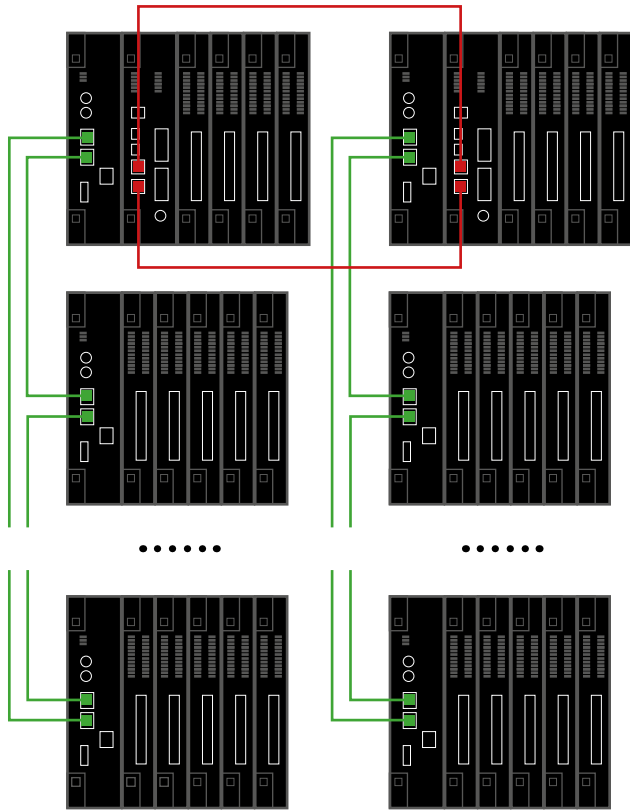

### CPU and Power Redundancy

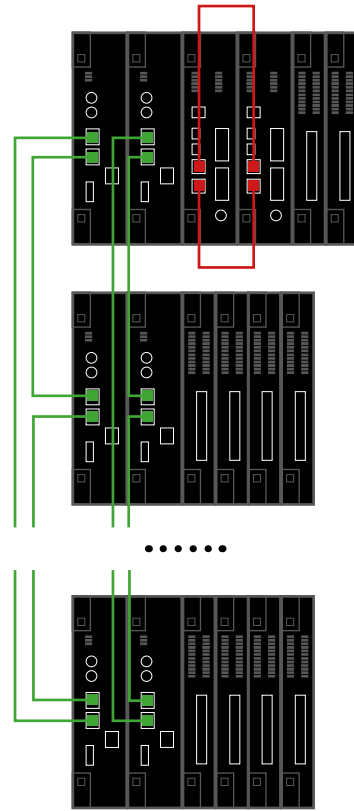

### Combined redundancy

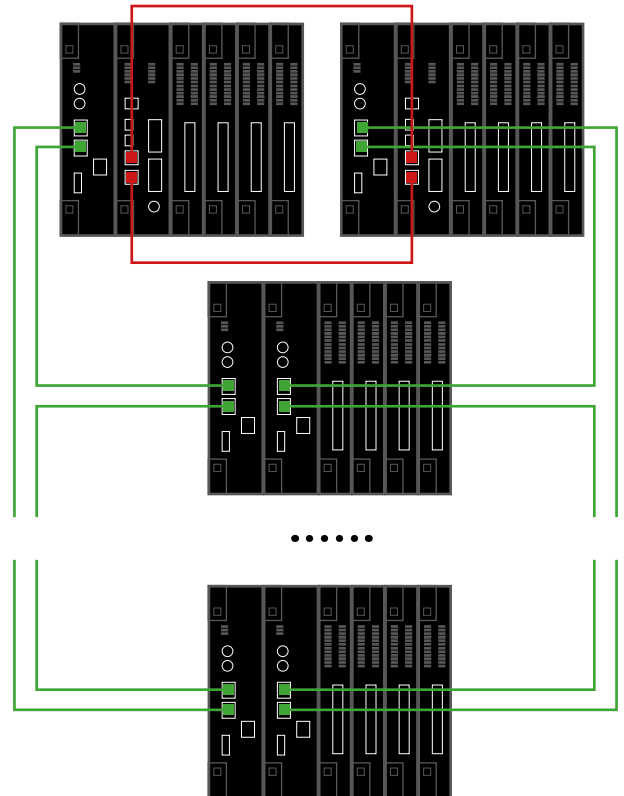
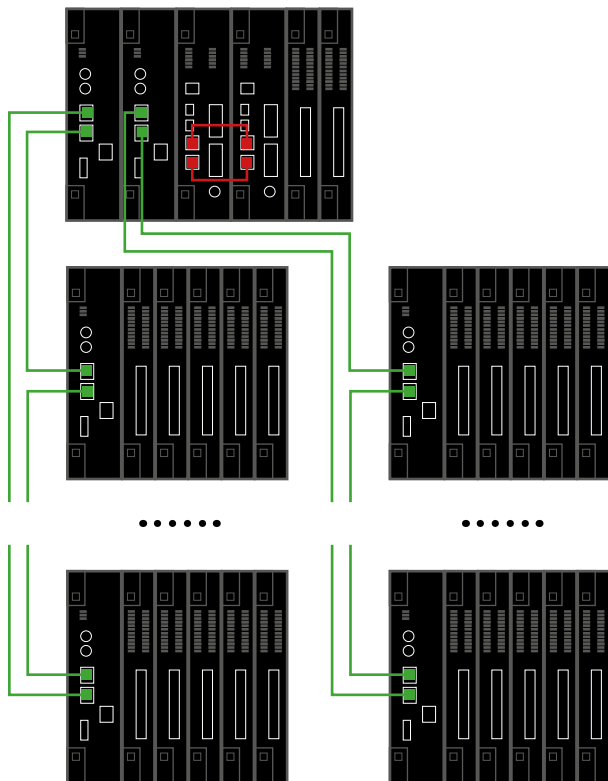



# Dimensional Drawings

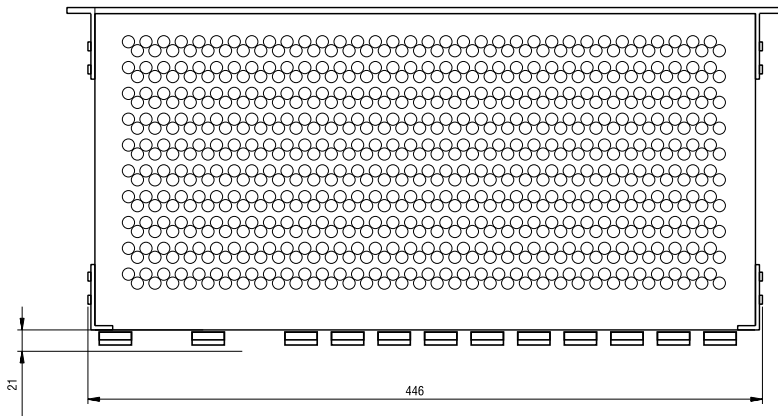
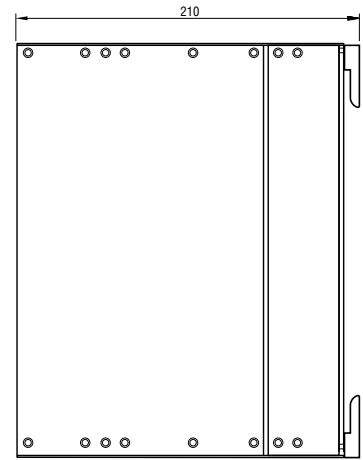
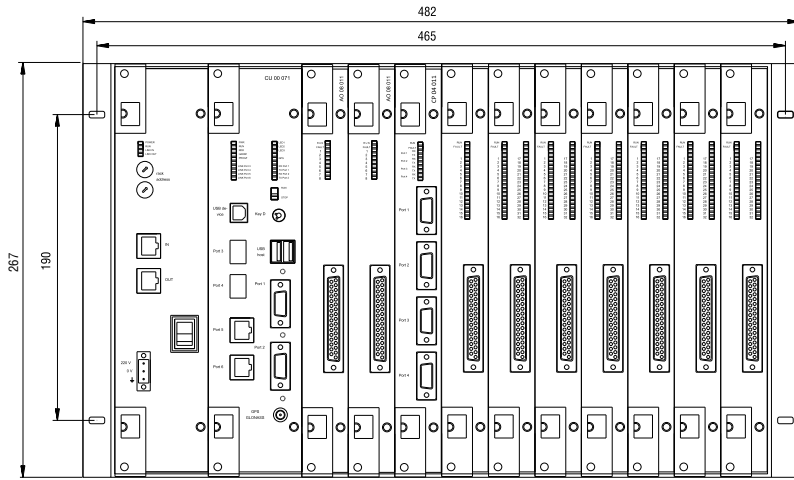

# REGUL R500 Programmable Logic Controller



Regul R500 is a fault-tolerant real-time programmable logic controller, designed for the use in process industries.

It features high-speed dual ring data bus, allowing fast collection of data for further processing, even with complex algorithms, without compromising on speed.

Its flexibility of communications and a special focus on redundancy, instrument-free replacement of hot-swappable modules, make it controller of choice when processes must go uninterrupted.

<p><b>Applications</b></p>	<ul style="list-style-type: none"> <li>• Fault-tolerant process control systems for             <ul style="list-style-type: none"> <li>– Steam and gas turbines (control and emergency protection)</li> <li>– Oil pumping stations and gas compressors</li> <li>– Main and auxiliary systems at power stations</li> <li>– Fire and gas systems</li> <li>– Water management systems</li> </ul> </li> <li>• Fiscal applications (for example, LACT units)</li> <li>• Applications with unstable connection to SCADA</li> <li>• Applications with large number of tags sent to SCADA</li> </ul>
<p><b>Redundancy</b></p>	<ul style="list-style-type: none"> <li>• Hot swapping of all modules</li> <li>• Hot-standby CPU modules</li> <li>• Dual ring high-speed internal data bus</li> <li>• Automatic power distribution between power supply modules</li> <li>• Redundancy of internal bus, CPU, CPU interconnection, I/O modules, power supply modules, SCADA connection</li> <li>• Hybrid counter/digital modules with support of 2oo3 voting at the level of modules</li> </ul>
<p><b>Features</b></p>	<p>General</p> <ul style="list-style-type: none"> <li>• Real-time programmable logic controller</li> <li>• Modular configuration, allowing flexible extension and change of configuration</li> <li>• Supports up to 130,000 channels</li> <li>• In-module event archiving</li> </ul> <p>Processing power and redundancy</p> <ul style="list-style-type: none"> <li>• Minimum application cycle time – 1 ms (5 ms with redundancy)</li> <li>• Scan time – 1 ms</li> <li>• Switchover in 5 ms</li> <li>• Processing of complex algorithms with powerful CPU modules and built-in microprocessors in I/O modules</li> </ul> <p>System configuration</p> <ul style="list-style-type: none"> <li>• Up to 40 modules in a rack, up to 255 racks, up to 10 km (via fiberoptic line) between racks</li> <li>• RJ-45, SFP, or mixed connection between racks</li> <li>• Star, ring, or mixed network topologies</li> <li>• CPU module can be placed into any rack</li> </ul> <p>Programming and visualization</p> <ul style="list-style-type: none"> <li>• Programming with IEC 61131-3 languages + CFC in Epsilon LD software</li> <li>• Online application update</li> <li>• Remote configuration/maintenance and application updates</li> <li>• Special firmware with MySQL database server</li> <li>• CPU module with DVI output for connecting a display and using Target-visualization</li> <li>• Web visualization option in CPU modules</li> </ul>

<b>Communications</b>	<p>Supported interfaces</p> <ul style="list-style-type: none"> <li>• RS-232 (9-pin, full duplex, speed 300-115, 200 bps, opto-isolation 500/1500 V, overvoltage protection)</li> <li>• RS-422/RS-485 (9-pin, speed 300-115, 200 bps, full-channel opto-isolation 500/1500 V, overvoltage protection): up to 96 ports per controller</li> <li>• Ethernet 10/100/1000 RJ-45 (full duplex): up to 4 ports per CPU</li> <li>• Ethernet 10/100/1000 fiberoptic (single-mode, multi-mode): up to 2 ports per CPU</li> </ul> <p>Built-in communication protocols*</p> <ul style="list-style-type: none"> <li>• IEC 60870-5-101 (master/slave)</li> <li>• IEC 60870-5-104 (master/slave)</li> <li>• Modbus RTU (master/slave, with expansion capabilities)</li> <li>• Modbus TCP (master/slave, with expansion capabilities)</li> <li>• OPC DA, OPC UA</li> </ul> <p><i>* Additional communication protocols, including non-standard ones, can be implemented according to your requirements.</i></p>																										
<b>Design</b>	<ul style="list-style-type: none"> <li>• Mid-size dimensions: 40×180×145 mm (W×H×D)</li> <li>• Detachable terminal blocks</li> <li>• Installation on a 105-mm DIN rail, with a clamp</li> <li>• Passive cooling; no mechanical or rotating structural components</li> </ul>																										
<b>Specifications</b>	<table border="1"> <tr> <td>• Minimum application cycle time</td> <td>1 ms (5 ms in redundant configuration)</td> </tr> <tr> <td>• Bus scan time</td> <td>1 ms</td> </tr> <tr> <td>• Time stamping accuracy</td> <td>from 1 ms</td> </tr> <tr> <td>• Switchover time from main to standby controller</td> <td>From 5 ms (1-2 cycles)</td> </tr> <tr> <td>• Timing accuracy</td> <td>50 μs</td> </tr> <tr> <td>• Processor</td> <td>Intel Atom, ARM Cortex-Axx</td> </tr> <tr> <td>• RAM</td> <td>2 GB, 512 MB</td> </tr> <tr> <td>• Flash memory (CU 00021, 031)</td> <td>1 GB</td> </tr> <tr> <td>• SSD (CU 00051, 061, 071)</td> <td>4 GB (optional up to 64 GB)</td> </tr> <tr> <td>• Input power</td> <td> <ul style="list-style-type: none"> <li>• 85...264 VAC</li> <li>• 18...36 VDC</li> <li>• 120...370 VDC</li> </ul> </td> </tr> <tr> <td>• I/O module size (W x H x D)</td> <td>40 × 180 × 145 mm</td> </tr> <tr> <td>• Operating temperature range</td> <td>0...+60°C</td> </tr> <tr> <td>• Approvals</td> <td>CE, EAC, GOST-R, FCC-ready</td> </tr> </table>	• Minimum application cycle time	1 ms (5 ms in redundant configuration)	• Bus scan time	1 ms	• Time stamping accuracy	from 1 ms	• Switchover time from main to standby controller	From 5 ms (1-2 cycles)	• Timing accuracy	50 μs	• Processor	Intel Atom, ARM Cortex-Axx	• RAM	2 GB, 512 MB	• Flash memory (CU 00021, 031)	1 GB	• SSD (CU 00051, 061, 071)	4 GB (optional up to 64 GB)	• Input power	<ul style="list-style-type: none"> <li>• 85...264 VAC</li> <li>• 18...36 VDC</li> <li>• 120...370 VDC</li> </ul>	• I/O module size (W x H x D)	40 × 180 × 145 mm	• Operating temperature range	0...+60°C	• Approvals	CE, EAC, GOST-R, FCC-ready
• Minimum application cycle time	1 ms (5 ms in redundant configuration)																										
• Bus scan time	1 ms																										
• Time stamping accuracy	from 1 ms																										
• Switchover time from main to standby controller	From 5 ms (1-2 cycles)																										
• Timing accuracy	50 μs																										
• Processor	Intel Atom, ARM Cortex-Axx																										
• RAM	2 GB, 512 MB																										
• Flash memory (CU 00021, 031)	1 GB																										
• SSD (CU 00051, 061, 071)	4 GB (optional up to 64 GB)																										
• Input power	<ul style="list-style-type: none"> <li>• 85...264 VAC</li> <li>• 18...36 VDC</li> <li>• 120...370 VDC</li> </ul>																										
• I/O module size (W x H x D)	40 × 180 × 145 mm																										
• Operating temperature range	0...+60°C																										
• Approvals	CE, EAC, GOST-R, FCC-ready																										

## Central Processor Unit (CPU) Modules

	CU 00 021	CU 00 031	CU 00 051	CU 00 061	CU 00 071
Redundant operation	Limited	Limited	Complete	Complete	Complete
Processor type	ARM Cortex-Axx	ARM Cortex-Axx	Intel Atom	Intel Atom	Intel Atom
RAM	512 Mb	512 Mb	2 GB	2 GB	2 GB
Flash memory	1 GB	1 GB	-	-	-
SSD	-	-	4 GB	4 GB	4 GB
Serial ports	<ul style="list-style-type: none"> <li>• 1 x RS232</li> <li>• 1 x RS485</li> </ul>	<ul style="list-style-type: none"> <li>• 1 x RS232</li> <li>• 1 x RS485</li> </ul>	<ul style="list-style-type: none"> <li>• 1 x RS232</li> <li>• 1 x RS485</li> </ul>	<ul style="list-style-type: none"> <li>• 1 x RS232</li> <li>• 1 x RS485</li> </ul>	<ul style="list-style-type: none"> <li>• 1 x RS232</li> <li>• 1 x RS485</li> </ul>
Network ports	2 x Ethernet RJ45	2 x Ethernet FO	4 x Ethernet RJ45	<ul style="list-style-type: none"> <li>• 2 x Ethernet RJ45</li> <li>• 2 x Ethernet FO</li> </ul>	<ul style="list-style-type: none"> <li>• 2 x Ethernet RJ45</li> <li>• 2 x Ethernet FO</li> </ul>
Integrated MySQL database	-	-	-	-	Yes
USB host	-	-	2 ports	2 ports	2 ports
DVI port	-	-	-	-	Yes
GPS / Glonass receiver	-	-	Yes	Yes	Yes
Approvals	CE, EAC, GOST-R, FCC-ready	CE, EAC, GOST-R, FCC-ready	CE, EAC, GOST-R, FCC-ready	CE, EAC, GOST-R, FCC-ready	CE, EAC, GOST-R, FCC-ready

## Analog Modules

	AI 16 011	AI 16 081	AI 08 031	AI 08 131	AI 08 041
Type	Analog Input	Analog Input	Analog Input	Analog Input	Analog Input
Number of channels	16	16 (2 x 8 channels)	8	8	8
Current measuring range	<ul style="list-style-type: none"> <li>0...20 mA</li> <li>4...20 mA</li> </ul>	<ul style="list-style-type: none"> <li>4...20 mA</li> </ul>	-	-	<ul style="list-style-type: none"> <li>0...20 mA</li> <li>4...20 mA</li> </ul>
Voltage measuring range	-	-	-	-	<ul style="list-style-type: none"> <li>0...+10 V</li> <li>-10...+10 V</li> </ul>
Thermocouples	-	-	R, S, B, J, T, E, K, N, A-1, A-2, A-3, L, M	R, S, B, J, T, E, K, N, A-1, A-2, A-3, L, M	-
Thermal resistances	-	-	Cu50, Cu100, Pt50, Pt100, Ni50, Ni100	Cu50, Cu100, Pt50, Pt100, Ni50, Ni100	-
Resolution (incl.overflow)	14 bits	16 bits	24 bits	24 bits	16 bits
Operating error	± 0.1%	± 0.1%	± 0.1%	± 0.1%	± 0.025%
ADC/DAC	Shared	Per group	Shared	Shared	Per channel
HART	-	Yes, per group	-	-	-
Galvanic isolation	Common	Group	Common	Channel	Channel
Other	-	-	Serial channel scan	Parallel channel scan	-

	AI 08 052	AO 08 011	AO 08 031	AS 08 011	AO 08 021
Type	Analog Input	Analog Output	Analog Output	Analog, Hybrid	Analog Output
Number of channels	16	8	8	6 input / 2 output	8
Current measuring range	<ul style="list-style-type: none"> <li>0...20 mA</li> <li>4...20 mA</li> </ul>	-	-	<ul style="list-style-type: none"> <li>0...20 mA</li> <li>4...20 mA</li> </ul>	<ul style="list-style-type: none"> <li>0...20 mA</li> <li>4...20 mA</li> </ul>
Voltage measuring range	<ul style="list-style-type: none"> <li>-0...+10 V</li> <li>-10...+10 V</li> </ul>	-	-	<ul style="list-style-type: none"> <li>-0...+10 V</li> <li>-10...+10 V</li> </ul>	-
Current output range	-	<ul style="list-style-type: none"> <li>0...20 mA</li> <li>4...20 mA</li> </ul>	<ul style="list-style-type: none"> <li>0...20 mA</li> <li>4...20 mA</li> </ul>	<ul style="list-style-type: none"> <li>0...20 mA</li> <li>4...20 mA</li> </ul>	<ul style="list-style-type: none"> <li>0...20 mA</li> <li>4...20 mA</li> </ul>
Voltage output range	-	-	<ul style="list-style-type: none"> <li>-0...+10 V</li> <li>-10...+10 V</li> </ul>	<ul style="list-style-type: none"> <li>-0...+10 V</li> <li>-10...+10 V</li> </ul>	-
Resolution (incl.overflow)	16 bits	16 bits	16 bits	14 bits	16 bits
Operating error	± 0.1%	± 0.1%	± 0.1%	± 0.1%	± 0.1%
ADC/DAC	Shared	Per channel	Per channel	Shared	Per channel
HART	-	-	-	-	Yes
Galvanic isolation	Channel	Channel	Channel	Channel	Channel

## Digital Modules

	DI 32 011	DI 32 111	DI 16 021	DO 32 011	DO 16 021	DS 32 011
Type	Digital Input	Digital Input	Digital Input	Digital Output	Digital Output	Digital, Hybrid
Number of channels	32 (4 groups x 8 channels)	32 (4 groups x 8 channels)	16	32 (4 groups x 8 channels)	16	<ul style="list-style-type: none"> <li>24 input (3 groups x 8 channels)</li> <li>8 output (1 group)</li> </ul>
Voltage	24 VDC	24 VDC	220 VAC/VDC	24 VDC, 0.5 A	<ul style="list-style-type: none"> <li>220 VAC, 2 A</li> <li>220 VDC, 0.3 A</li> </ul>	24 VDC, 0.5 A
Galvanic isolation	Group	Group	Channel	Group	<ul style="list-style-type: none"> <li>Channel</li> </ul>	Group
Other	Common "-" in group	Common "+" in group	-	-	-	

## Counter Modules

	DA 03 011	DA 03 021
Number of channels	<ul style="list-style-type: none"> <li>• 3 x Frequency</li> <li>• 6 x Digital Input</li> <li>• 6 x Digital Output</li> </ul>	<ul style="list-style-type: none"> <li>• 3 x Frequency</li> <li>• 6 x Digital Input</li> <li>• 6 x Digital Output</li> <li>• 1 x Frequency Generator</li> </ul>
Channel supply voltage	4...24 V	5, 12, 24 V
Digital input, voltage	24 VDC	24 VDC
Digital output, voltage	24 VDC, 0.5A	24 VDC, 0.5A
Frequency measurement range	<ul style="list-style-type: none"> <li>• 1 Hz ... 500 kHz</li> <li>• 1 Hz ... 10 kHz</li> </ul>	<ul style="list-style-type: none"> <li>• 1 Hz ... 500 kHz</li> <li>• 1 Hz ... 10 kHz</li> </ul>
Pulse counting range	0 ... 2 <sup>64</sup>	0 ... 2 <sup>64</sup>
Operating error	± 0.01%	± 0.01%
Pulse-counting error	± 1 pulse	± 1 pulse
Galvanic isolation	Channel	Channel
Built-in firmware	<ul style="list-style-type: none"> <li>• Frequency counter up to 10 kHz with pulse counter</li> <li>• Frequency counter up to 500 kHz</li> <li>• Data processing from encoder</li> <li>• LACT unit</li> </ul>	<ul style="list-style-type: none"> <li>• Frequency counter up to 10 kHz with pulse counter</li> <li>• Frequency counter up to 500 kHz</li> <li>• Data processing from encoder</li> <li>• LACT unit</li> <li>• Electronic overspeed trip</li> </ul>

## Power Supply Modules

	PP 00 011	PP 00 021	PP 00 031
Voltage	24 VDC	24 VDC	220 VAC/VDC
Power	75 W	75 W	75 W
Galvanic isolation	-	Yes	Yes

## Communication Processor Modules

	CP 04 011	CP 02 021	CP 06 111
Ports	4	2	6
Interface	RS-485	RJ-45	RJ-45
Protocol	Modbus RTU	Modbus TCP, Ethernet	Regul bus

## Termination / Bus Extension Modules

	ST 00 001	ST 01 011	ST 01 021	ST 02 012	ST 02 022	ST 02 111	ST 02 121
Ports	-	1	1	2	2	2	2
Bus extension	-	Yes	Yes	Yes	Yes	Yes	Yes
Redundant bus	-	-	-	Yes	Yes	Yes	Yes
Type	Termination	IN	OUT	IN	OUT	IN	OUT
Interface	-	RJ-45	RJ-45	RJ-45	RJ-45	Fiberoptics	Fiberoptics

## Flexibility in Connecting Racks

- The R500 series support up to 255 extension racks and up to 40 modules in one rack
- Standby CPU module can be installed into the same rack as main CPU, into a similar CPU rack, or even into an I/O rack
- Maximum distance between racks can reach up to 10 km
- Synchronization between the CPUs can be done over Ethernet or fiberoptic connection
- Fiberoptic connection can be single-mode or multi-mode (please, consult with the table of tested adapters at our support team)
- Rack connection can be in form of:
  - Star
  - Line
  - Daisy chain
  - Ring
  - Dual ring
- System configuration also supports segmenting via communication processor modules
- In one system could be combined REGUL controllers from different series

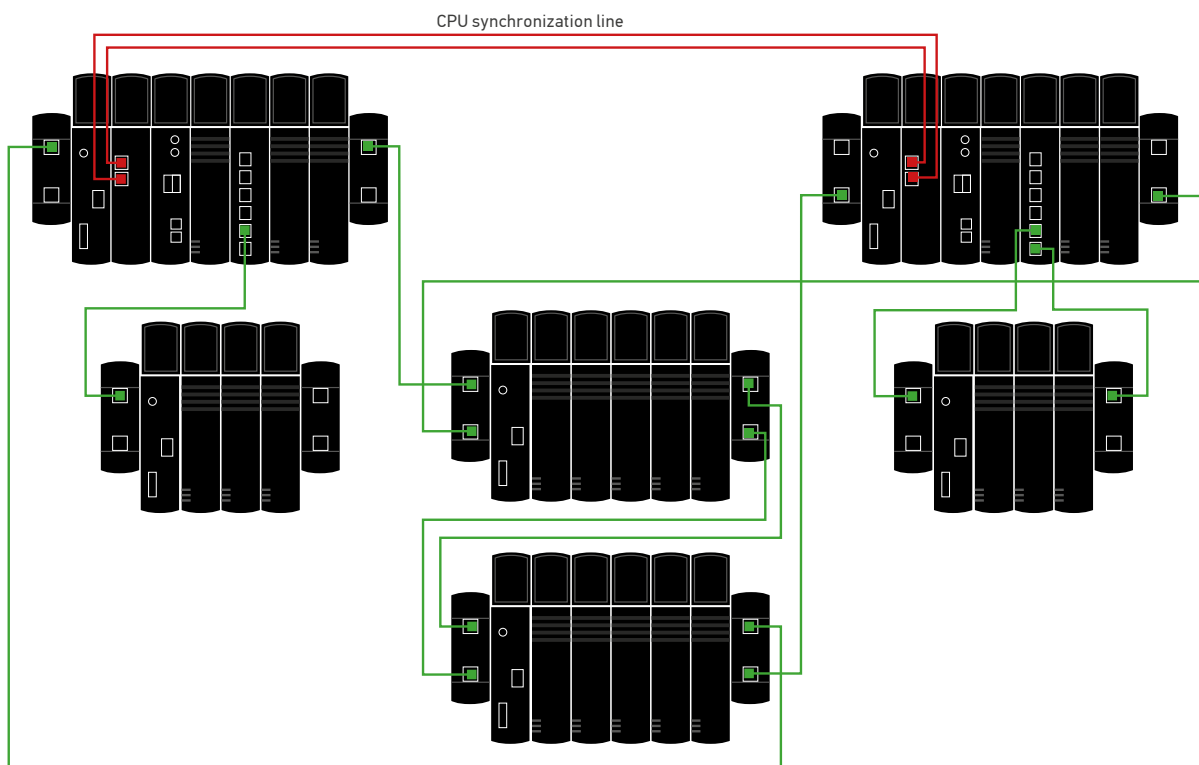



## Smart I/O Modules

Each input/output module in the REGUL R500 series holds two independent ports for communicating with CPU modules over Regul bus. This allows information to be delivered from modules simultaneously to active and standby CPU and provide instant switchover.

The primary processing of a signal is performed in the module and includes:

- Signal diagnostics for range overshooting and abrupt value changes
- De-jittering function for digital signals
- Programmable averaging time
- Signal conversion values in engineering units
- Monitoring for a short-circuit or open input circuit of analog signals
- Monitoring for an open output circuit of analog signals
- Configuration of output presets

## Redundancy

### Major features

- CPU modules operate in hot standby mode, with parallel execution of application
- Switchover is done in 1-2 cycles
- Dual ring bus tolerates several bus failures without loss of control
- I/O modules communicate with each of the CPU modules independently from their status
- Built-in protection from two masters in one system
- The system can tolerate multiple reasons of failures

### Conditions to transfer control

- Operator stopped application on the active CPU
- Operator requested a switchover from the configuration software
- An error was identified on the bus
- Communication to the active CPU was lost

### Optional configurations

- Dual sync connection between the CPUs provides additional layer of protection
- Multiple power supply modules (two or more) provide power even in most difficult situations
- Dual SCADA connection and large local data storage deliver redundancy of operation on an unstable communication channel
- I/O modules can be installed in a mirror/duplicate configuration for continuous operation in case of I/O failure

## REGUL R500 Redundancy Schemes

100% Mirror Redundancy

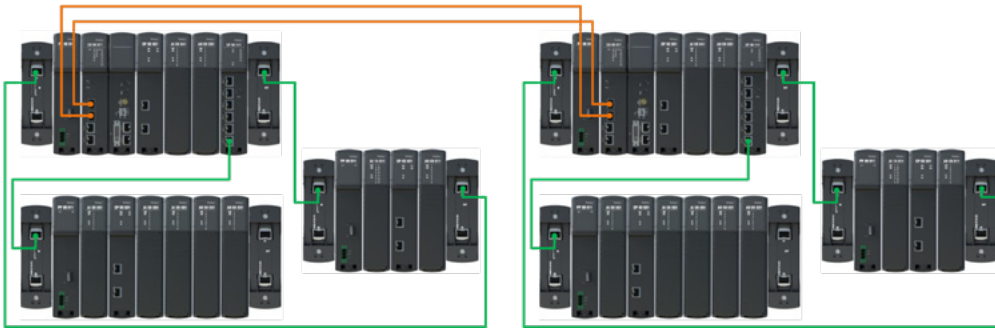

One CPU rack with shared I/O racks

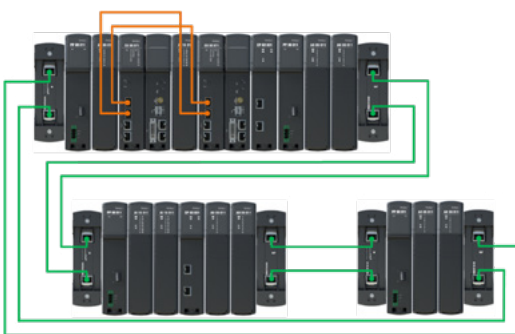

100% CPU redundancy, shared I/Os

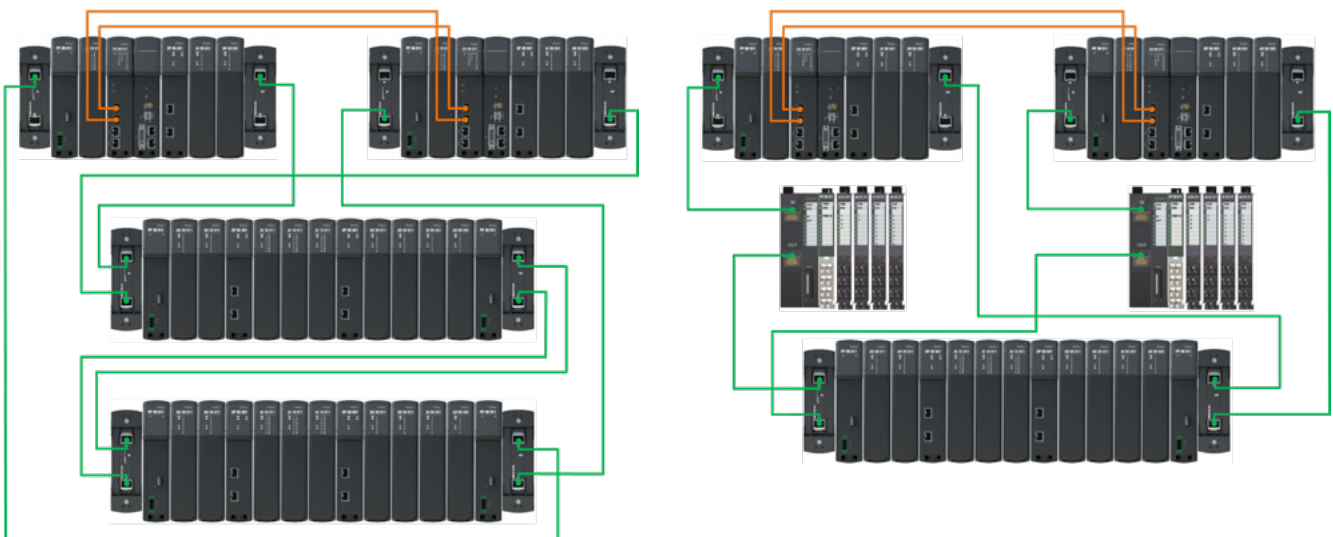

## Dimensional Drawings

### Input/Output, Power Supply, Communication Processor Modules

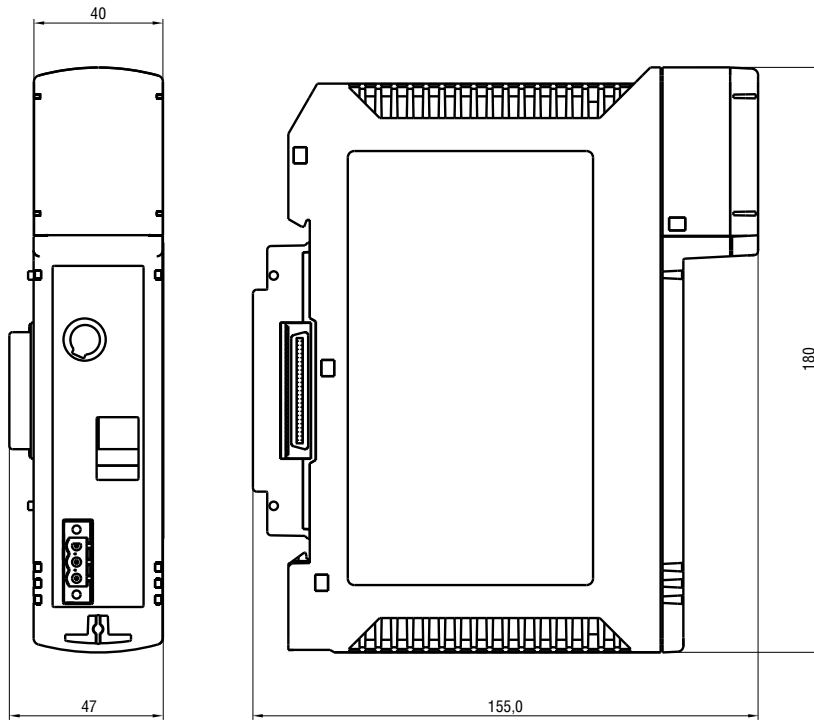

### CPU Modules

- CU 00 051
- CU 00 061
- CU 00 071

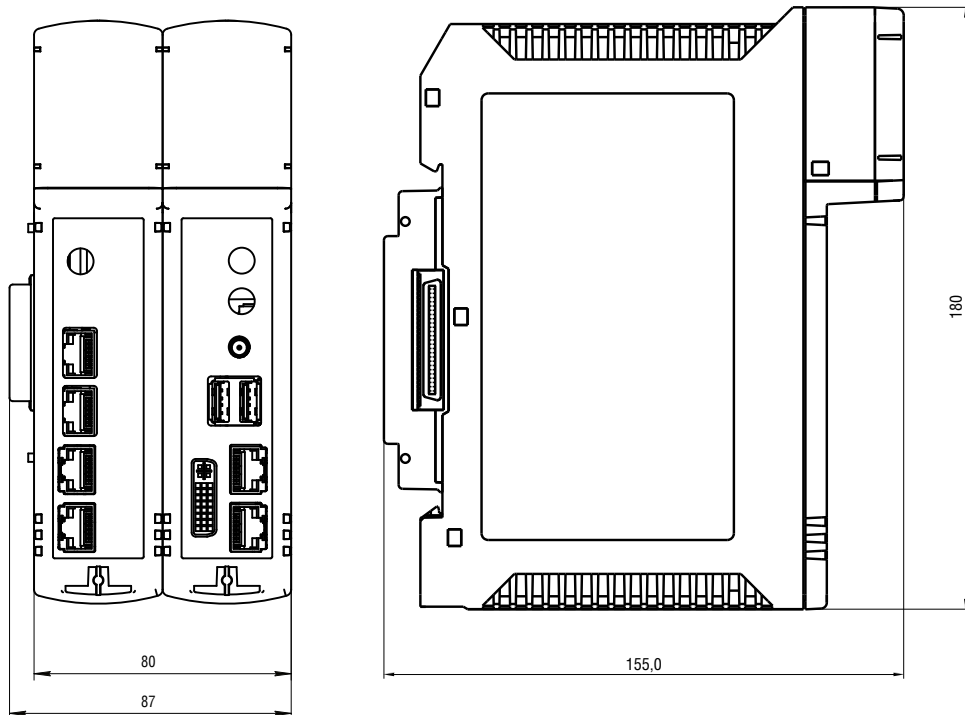

Bus Extension Modules, RJ-45

ST 00 001  
ST 02 012  
ST 02 022

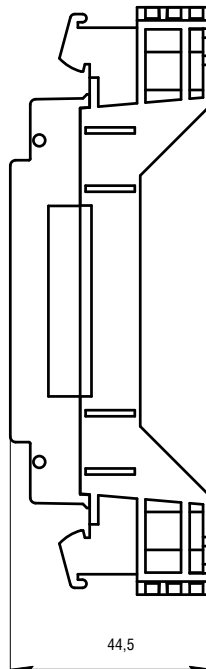
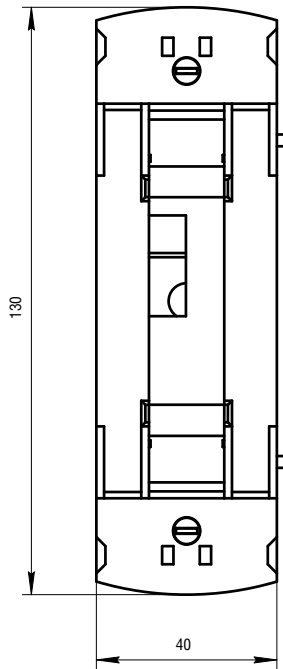

Bus Extension Modules, Fiberoptic

ST 02 111  
ST 02 121

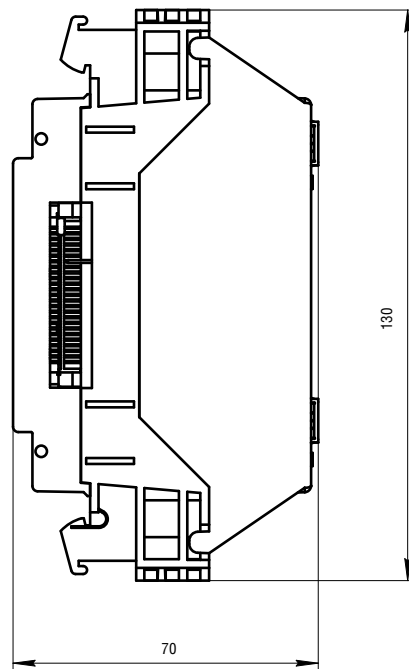
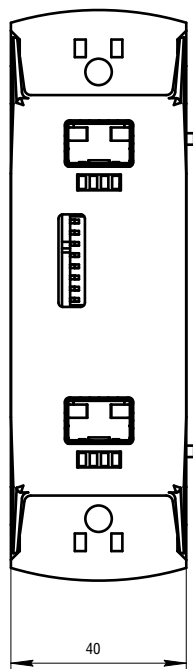

# REGUL R400 HMI/Programmable Logic Controller



The REGUL R400 controller is a combination of a human-machine interface (HMI) and a CPU in one module. Internally it shares most of the electronic part with R500 CU 071 CPU module. Internal bus supports ring operation and the device can operate in one system with I/O module of any other REGUL series.

<b>Applications</b>	Standalone and distributed automation systems with visualization	
<b>Features</b>	<ul style="list-style-type: none"> <li>• Display of visualization created in Epsilon LD</li> <li>• Internal SSD for user archives</li> <li>• Connecting expansion racks of Regul RX00 series controllers</li> <li>• Supports up to 255 expansion racks</li> <li>• Extended temperature range</li> <li>• Programming with five IEC 61131-3 languages in Epsilon LD softwares</li> </ul>	
<b>Design</b>	<ul style="list-style-type: none"> <li>• 7" touchscreen display</li> <li>• IP66 ingress protection for the front panel</li> <li>• Steel housing</li> <li>• Rack- or door-mount</li> <li>• Membrane keyboard</li> </ul>	
<b>Specifications</b>	Display size	7"
	Display resolution	800 × 480
	Colors	16.7 M
	Touchscreen type	Capacitive
	Processor type	Intel Atom
	RAM	2 GB
	SSD	4 GB
	Interfaces	<ul style="list-style-type: none"> <li>• 1 × RS-485</li> <li>• 1 × DVI</li> <li>• 2 × USB host</li> <li>• 2 × Ethernet RJ-45</li> <li>• 2 × Regul bus (IN, OUT)</li> </ul>
	Input power	18...36 VDC
	Operating temperature range	-20...+40 °C
	Approvals	CE, EAC, GOST-R

## Hardware Configuration

- Supports up to 255 expansion racks
- Additional racks could be connected via star or ring topology

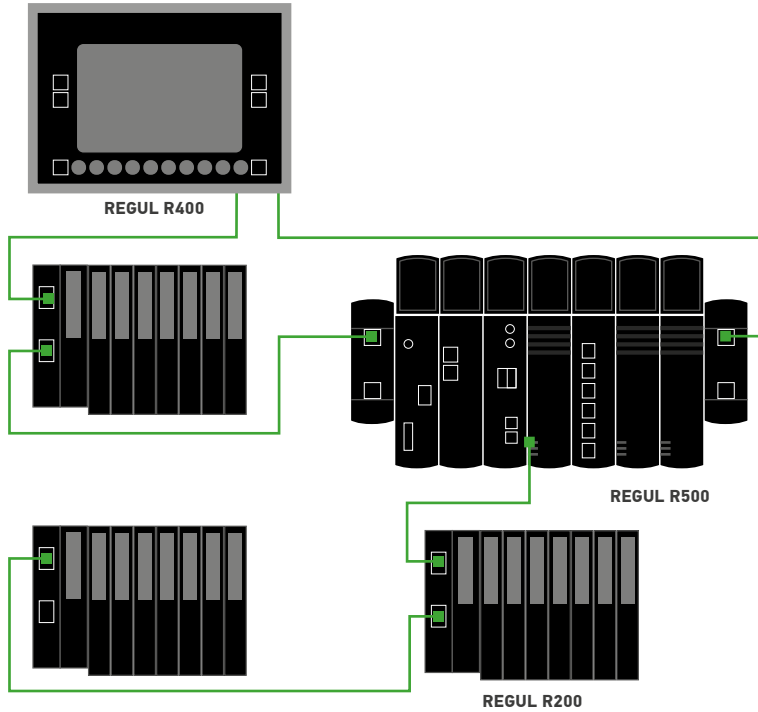

## Dimensional Drawings

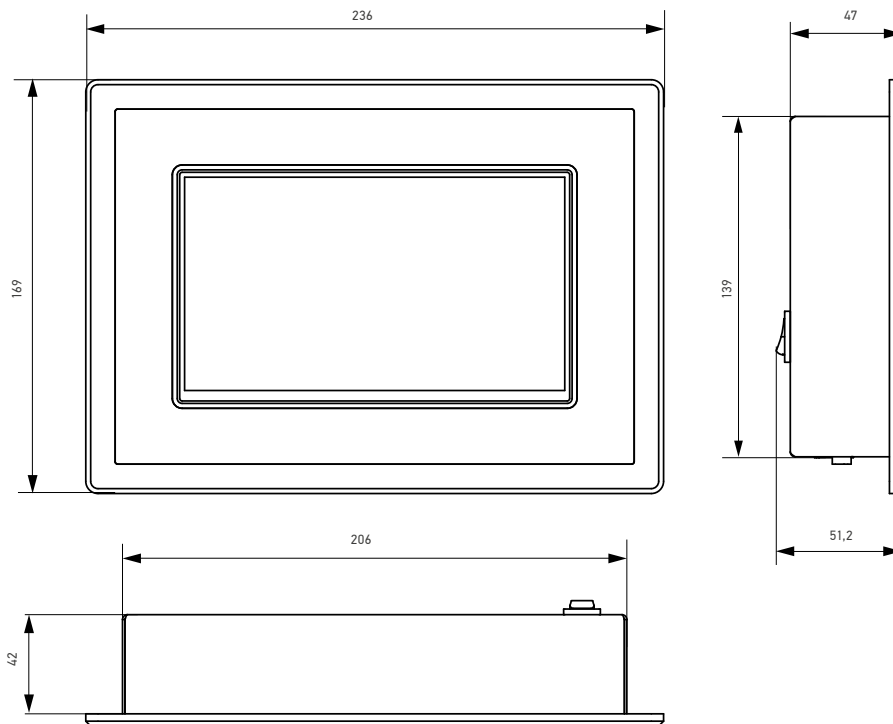

*Dimensions of the panel's cutout for mounting the R400: WxH = 210±2 x 145±2 mm.*



# REGUL R200 Programmable Logic Controller



Regul R200 programmable logic controller (PLC) was developed for the use in industrial conditions and operates in the temperatures from  $-40$  to  $+60$  °C and electromagnetic interference. Each module passes a burn-in test, which is carried out at  $50$ ° C for 48 hours.

User application runs in real time and inside a selected real-time operating system.

Any I/O module in the system could be replaced in hot-swap – without stopping the user application. During replacement, terminal block remains intact, reducing maintenance time. Extendability is up to 80 I/O modules per rack and up to 255 racks.

Programming can be done in one of the five IEC 61131-3 languages or in CFC. The Epsilon LD is a familiar programming environment for many and is available free of charge.

<b>Applications</b>	<ul style="list-style-type: none"> <li>• Small- and medium-sized (based on number of signals) I/O systems</li> <li>• Compact solutions</li> <li>• Remote I/O</li> </ul>																		
<b>Features</b>	<ul style="list-style-type: none"> <li>• Hot-swapping of all controller modules</li> <li>• Modular configuration, allowing flexible extension and change of configuration</li> <li>• Up to 70 modules in one rack</li> <li>• Interoperability with other REGUL PLCs on the shared bus or added bus segment</li> <li>• Extended temperature range</li> <li>• Programming with five IEC 61131-3 languages, in Epsilon LD software</li> </ul>																		
<b>Communications</b>	<p>Supported interfaces</p> <ul style="list-style-type: none"> <li>• RS-232 (9-pin, full duplex, speed 300–115, 200 bps, opto-isolation 500/1500 V, overvoltage protection)</li> <li>• RS-422/RS-485 (9-pin, speed 300–115, 200 bps, full-channel opto-isolation 500/1500 V, overvoltage protection): up to 96 ports per controller</li> <li>• Ethernet 10/100/1000 RJ-45 (full duplex): up to 2 ports per CPU</li> <li>• Ethernet 10/100/1000 FO (single-mode, multi-mode): up to 1 port per CPU</li> </ul> <p>Built-in communication protocols</p> <ul style="list-style-type: none"> <li>• IEC 60870-5-101 (master/slave)</li> <li>• IEC 60870-5-104 (master/slave)</li> <li>• OPC DA/UA</li> <li>• Modbus RTU (master/slave, with expansion capabilities)</li> <li>• Modbus TCP (master/slave, with expansion capabilities)</li> </ul>																		
<b>Design</b>	<ul style="list-style-type: none"> <li>• Compact dimensions, 15 x 101 x 104 mm (WxHxD)</li> <li>• Convenient chassis—replace modules without disconnecting cables</li> <li>• Passive cooling; no mechanical or rotating components</li> <li>• Installation on a 35-mm DIN rail</li> <li>• Possibility of using locking and sealing elements for fiscal applications</li> <li>• Location coding according to the module type</li> </ul>																		
<b>Specifications</b>	<table border="1"> <tr> <td>Minimum application cycle time</td> <td>1 ms</td> </tr> <tr> <td>Timing accuracy</td> <td>50 <math>\mu</math>s (CU 00 041, CU 00 061)</td> </tr> <tr> <td>Processor type</td> <td>ARM Cortex Axx</td> </tr> <tr> <td>RAM</td> <td>512 MB</td> </tr> <tr> <td>Flash memory</td> <td>1 GB</td> </tr> <tr> <td>Input power</td> <td>18...36 VDC</td> </tr> <tr> <td>I/O module size (W x H x D)</td> <td>15 x 101 x 104 mm</td> </tr> <tr> <td>Operating temperature range</td> <td><math>-40</math>...<math>+60</math> °C</td> </tr> <tr> <td>Approvals</td> <td>CE, EAC, GOST-R, FCC-ready</td> </tr> </table>	Minimum application cycle time	1 ms	Timing accuracy	50 $\mu$ s (CU 00 041, CU 00 061)	Processor type	ARM Cortex Axx	RAM	512 MB	Flash memory	1 GB	Input power	18...36 VDC	I/O module size (W x H x D)	15 x 101 x 104 mm	Operating temperature range	$-40$ ... $+60$ °C	Approvals	CE, EAC, GOST-R, FCC-ready
Minimum application cycle time	1 ms																		
Timing accuracy	50 $\mu$ s (CU 00 041, CU 00 061)																		
Processor type	ARM Cortex Axx																		
RAM	512 MB																		
Flash memory	1 GB																		
Input power	18...36 VDC																		
I/O module size (W x H x D)	15 x 101 x 104 mm																		
Operating temperature range	$-40$ ... $+60$ °C																		
Approvals	CE, EAC, GOST-R, FCC-ready																		

## Central Processor Unit (CPU) Modules

	CU 00 021	CU 00 031	CU 00 041	CU 00 061
Redundant operation	-	-	Limited	Limited
Processor type	ARM Cortex-Axx	ARM Cortex-Axx	ARM Cortex-Axx	ARM Cortex-Axx
RAM	512 MB	512 MB	512 MB	512 MB
Flash memory	1 GB	1 GB	1 GB	1 GB
Regul bus	-	Line only	Line or ring	Line or ring
Serial ports	<ul style="list-style-type: none"> <li>1 x RS-232</li> <li>1 x RS-485</li> </ul>	<ul style="list-style-type: none"> <li>1 x RS-232</li> <li>1 x RS-485</li> </ul>	<ul style="list-style-type: none"> <li>1 x RS-232</li> <li>1 x RS-485</li> </ul>	<ul style="list-style-type: none"> <li>1 x RS-232</li> <li>1 x RS-485</li> </ul>
Network ports	1 x Ethernet RJ45	1 x Ethernet RJ45	2 x Ethernet RJ45	<ul style="list-style-type: none"> <li>1 x Ethernet RJ45</li> <li>1 x Ethernet FO</li> </ul>
GPS / Glonass receiver	-	-	Yes	Yes

Each R200 CPU module is supplied with one R200 PP 00 011 power supply module.

All models with index (W) include a web server with support of Web visualization (prepared in Epsilon LD software)

## Analog Modules

	AI 04 011	AI 02 031	AI 02 041	AI 04 051	AI 04 081
Type	Analog Input	Analog Input	Analog Input	Analog Input	Analog Input
Number of channels	4	2	2	4	4
Current measuring range	<ul style="list-style-type: none"> <li>0...20 mA</li> <li>4...20 mA</li> </ul>	-	<ul style="list-style-type: none"> <li>0...20 mA</li> <li>4...20 mA</li> </ul>	<ul style="list-style-type: none"> <li>0...20 mA</li> <li>4...20 mA</li> </ul>	<ul style="list-style-type: none"> <li>0...20 mA</li> <li>4...20 mA</li> </ul>
Voltage measuring range	-	-	<ul style="list-style-type: none"> <li>0...+10 V</li> <li>-10...+10 V</li> </ul>	<ul style="list-style-type: none"> <li>0...+10 V</li> <li>-10...+10 V</li> </ul>	<ul style="list-style-type: none"> <li>0...+10 V</li> <li>-10...+10 V</li> </ul>
Thermocouples	-	R, S, B, J, T, E, K, N, A-1, A-2, A-3, L	-	-	-
Thermal resistances	-	Cu50, Cu100, Pt50, Pt100, Ni50, Ni100	-	-	-
Resolution (incl.overflow)	24 bits	24 bits	24 bits	24 bits	24 bits
Operating error	± 0.1%	± 0.1%	± 0.025%	± 0.1%	± 0.1%
ADC/DAC	Shared	Shared	Per channel	Shared	Shared
HART	-	-	-	-	Yes
Galvanic isolation	Common	Common	Channel	Channel	Common

	AO 02 011
Type	Analog Output
Number of channels	2
Output range, current	<ul style="list-style-type: none"> <li>0...20 mA</li> <li>4...20 mA</li> </ul>
Output range, voltage	-
Resolution (incl.overflow)	16 bits
Operating error	± 0.1%
ADC/DAC	Per channel
Galvanic isolation	Channel

## Digital Modules

	DI 08 011	DO 08 011	DO 04 021
Type	Digital Input	Digital Input	Digital Output
Number of channels	8	8	4
Current	24 VDC	24 VDC / 0.5 A	<ul style="list-style-type: none"> <li>• 220 VAC / 2 A</li> <li>• 220 VDC / 0.3 A</li> </ul>
Galvanic isolation	Common	Common	Channel

## Counter Modules

	DA 01 011
Number of channels	<ul style="list-style-type: none"> <li>• 1 x Frequency</li> <li>• 2 x Digital Input</li> <li>• 2 x Digital Output</li> </ul>
Channel supply voltage	5, 12, 24 V
Digital input, current	24 VDC
Digital output, current	24 VDC, 0.5A
Frequency measurement range	<ul style="list-style-type: none"> <li>• 1 Hz ... 100 kHz</li> </ul>
Pulse counting range	0 ... 2 <sup>64</sup>
Operating error	± 0.01%
Pulse-counting error	± 1 pulse
Galvanic isolation	Channel
Built-in firmware	<ul style="list-style-type: none"> <li>• Frequency counter up to 10 kHz with pulse counter</li> <li>• Frequency counter up to 500 kHz</li> <li>• Data processing from encoder</li> <li>• LACT unit</li> <li>• Electronic overspeed trip</li> </ul>

## Other Modules

	PP 00 011	ST 00 011	CP 01 011
Type	Power supply	Bus extension	Communication
Voltage	24 VDC		
Power	15 W		
Ports	-	2	1
Interface	-	RJ-45	RS-485
Protocol	-	Regul bus	Modbus RTU
Other	-	Includes one PP 00 011 module	-

# Hardware Configuration

Mixed Topology – Star and Ring, with REGUL R500

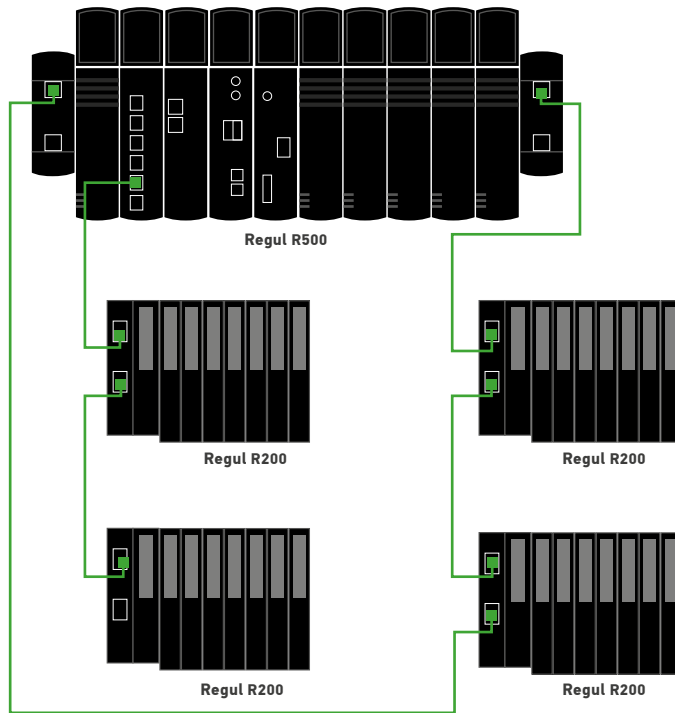

Ring Topology

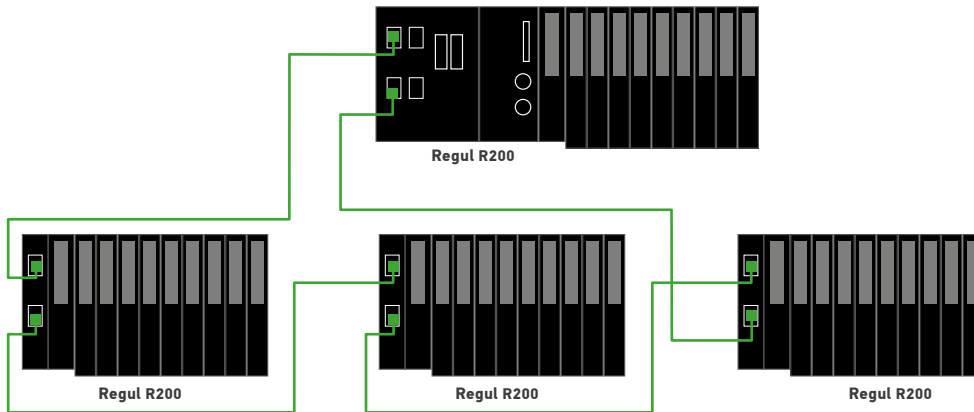

Star Topology

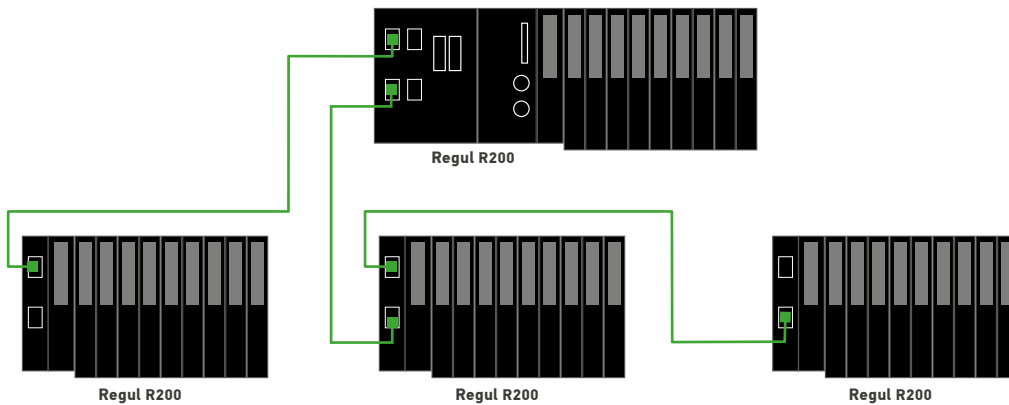

## Dimensional Drawings

### Input/Output and Communication Processor Modules

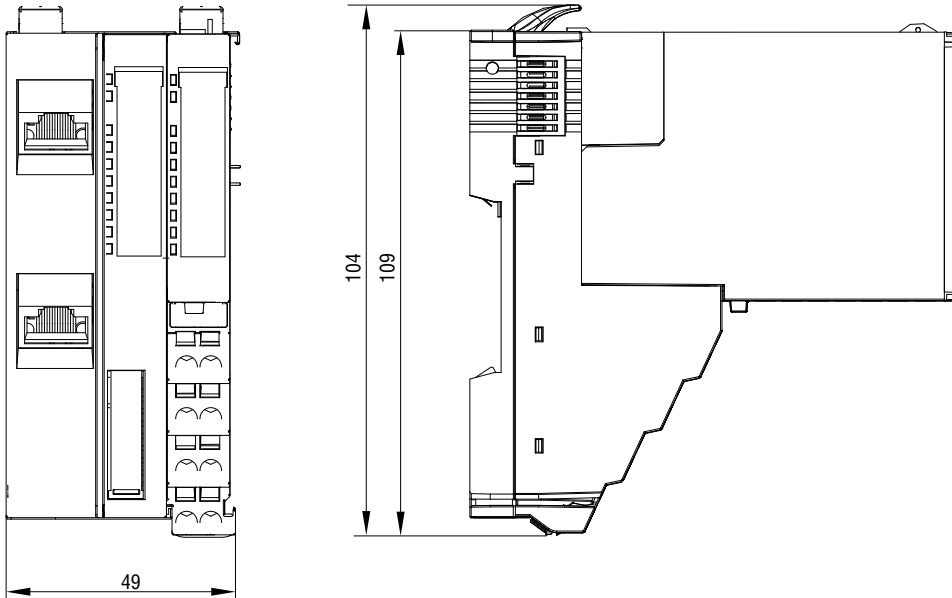

### CPU Modules

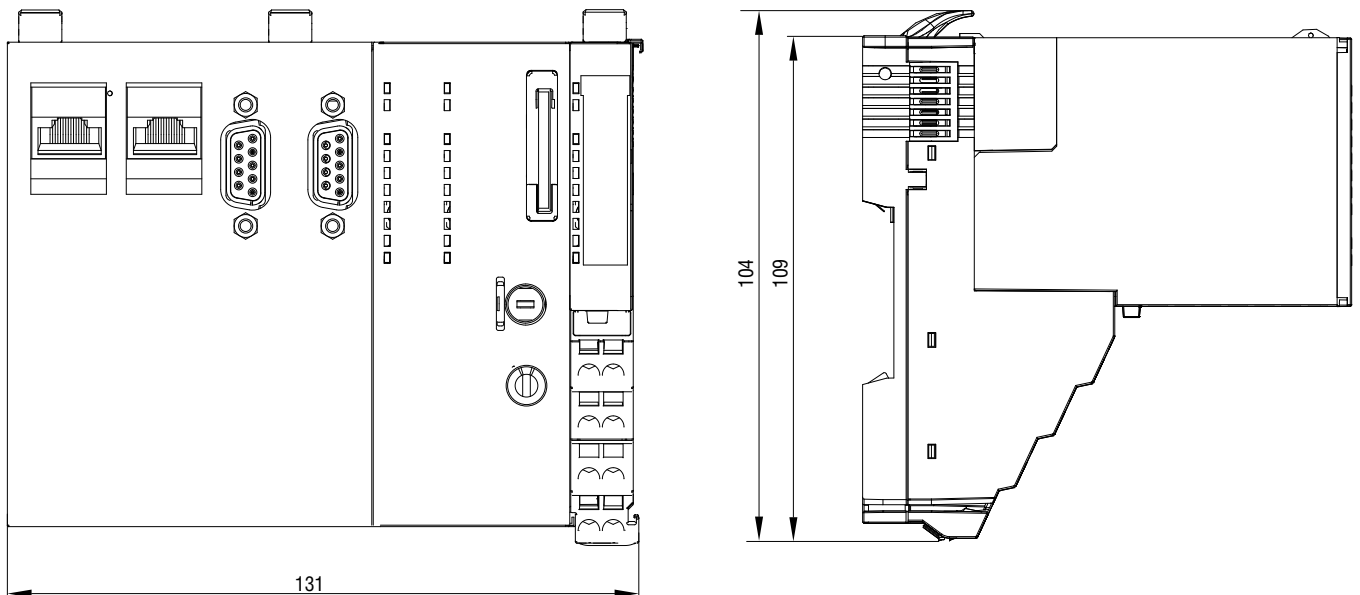

# REGUL R500S Safety (SIL3) Programmable Logic Controller



In some industries it is extremely important to ensure reliable protection of personnel, process equipment, and the environment in case an emergency situation occurs at the facility that can lead to an accident. In these areas, using regular distributed control system (DCS) tools is not enough to automate the technological processes. An independent emergency shutdown system (ESD) must also be used. Industry standards impose very strict requirements on ESD systems and the controllers on which they are based. These requirements are reasonable but also difficult to comply with.

Engineers at GP Systems GmbH have many years of experience in developing systems with pre-fault safety functions for various hazardous production facilities. In addition, GP Systems GmbH has experience in development and manufacturing its own range of REGUL RX00 controllers, which include solutions for continuous production. Developing the REGUL R500S specialized controller for emergency control systems involved combining existing knowledge in the emergency automation field and a large database of technical solutions and know-how regarding controller equipment.

The new REGUL R500S controller is based on the platform of the existing commercially available

controller, but it is an entirely new product developed according to the IEC 61508 standard.

To develop the controller in accordance with the strict requirements of the standard, our engineers received additional training. Experts certified by the TÜV company were also involved in the development process.

According to the IEC 61508 requirements, when developing the controller, deep analysis is required of the current progress, plans, design, and actual operation at all stages of the product life cycle. Careful analysis of hazards and risks is mandatory at the design and development stages. Data processing and reliability calculation are carried out using specialized certified software.

The REGUL R500S controller hardware fully conforms to the functional SIL3:

- The controller provides everything necessary to ensure the reliability of the ESD systems: the independent hardware watchdog, hardware backup of various types (duplication, triplication), functional redundancy, and diagnostics and analysis systems with a comparison function to compare the values of technologically related parameters.
- The controller provides comprehensive self-diagnostics that allows it to detect an internal failure and ensure that the entire process control system switches to the predetermined safe state.
- Each input/output module has a built-in microprocessor that is certified for use in functional SIL3 systems and performs tasks related to functional safety.
- Each controller module is powered with two internal buses. At the same time, constant diagnostics are carried out on the supply voltage. If failure occurs, the information is sent to the operating personnel, while the controller continues to operate and perform the functions of monitoring and control without switching to the safe state.

In addition to the self-diagnostic systems, the REGUL R500S controller offers developers a wide range of tools for monitoring the measurement and control of circuit parameters:

- Sensor channel power monitoring with short-circuit and overload protection.
- Digital input modules according to the NAMUR specification.
- Digital output modules with circuit current monitoring. This in-depth, proactive diagnostics allows for early detection and evaluation of a failure, which, in turn, gives the operator time for troubleshooting.



To ensure continuous operation of process equipment, the REGUL R500S controller provides the use of backup input/output modules, called backup assemblies, that consist of two or three modules of the same type.

The channel capacity of the assembly modules at the application program level is combined according to the duplication or triplication method; that is, one input or output logic variable corresponds to two (or three) physical channels. The resulting redundancy allows the user to reduce the number of safe failures (failures caused not by an emergency situation

at the facility but by a failure of the ESD system), including field and controller equipment. It allows for rapid replacement of duplicated system components without shutting down the process.

The presence of two independent data buses in the controller allows for the implementation of SIL3 high-availability systems on the basis of the controller. Such systems configured according to the 1oo2 scheme are used at high-risk facilities with a continuous process cycle. Any single failure in such systems does not lead to the command issue to switch the system to the safe state.

## Software architecture of the REGUL R500S controller

- Control is carried out by a specialized operating system certified for use in the equipment of functional SIL3.
- Built-in system software is developed by GP Systems GmbH in accordance with the IEC 61508 standard requirements.
- The development environment is also a product of GP Systems GmbH based on Epsilon LD. It has its own built-in safety editor and compiler made in accordance with the requirements of IEC 61508.

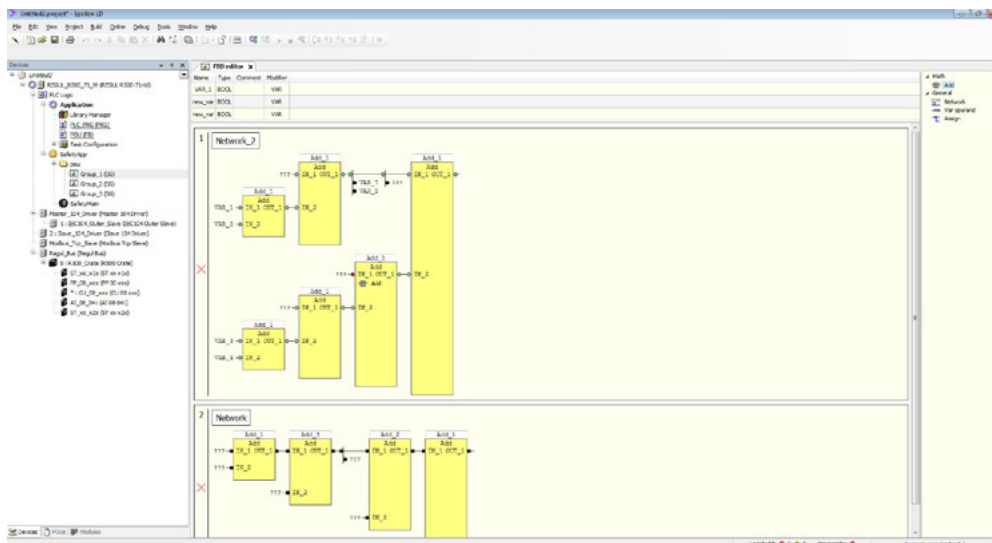

All developed software is tested with certified static analysis tools for compliance with the MISRA C:2012.

# REGUL R000 Managed Switch



Extends internal data bus for REGUL RX00 controllers. Allows to segment internal data bus to improve resistance to failures.

Converts physical level of the signal (optical to electrical).

### Features

- Connect up to three “rings” or up to six “stars”, or combinations of these schemes
- Identify losses and/or data distortions in the network segments and isolate corresponding segment
- Control (open, close) remotely ports of the switch
- Obtain diagnostic data on connection status
- Use up to two power supplies

### Design

- Case with the dimensions of 40 x 180 x 145 mm
- Mounting on a 105 mm DIN rail
- Passive cooling; no mechanical or rotating structural components

## Technical Specifications

	R000 CP 06 111	R000 CP 06 121
Inbound interfaces	2 x RJ-45	2 x Fiberoptic
Extension interfaces	6 x RJ-45	6 x RJ-45
Power supply	18-32 VDC	18-32 VDC
Operating temperature range	-40 ... +60°C	-40 ... +60°C

## REGUL R000 – Examples of Connection

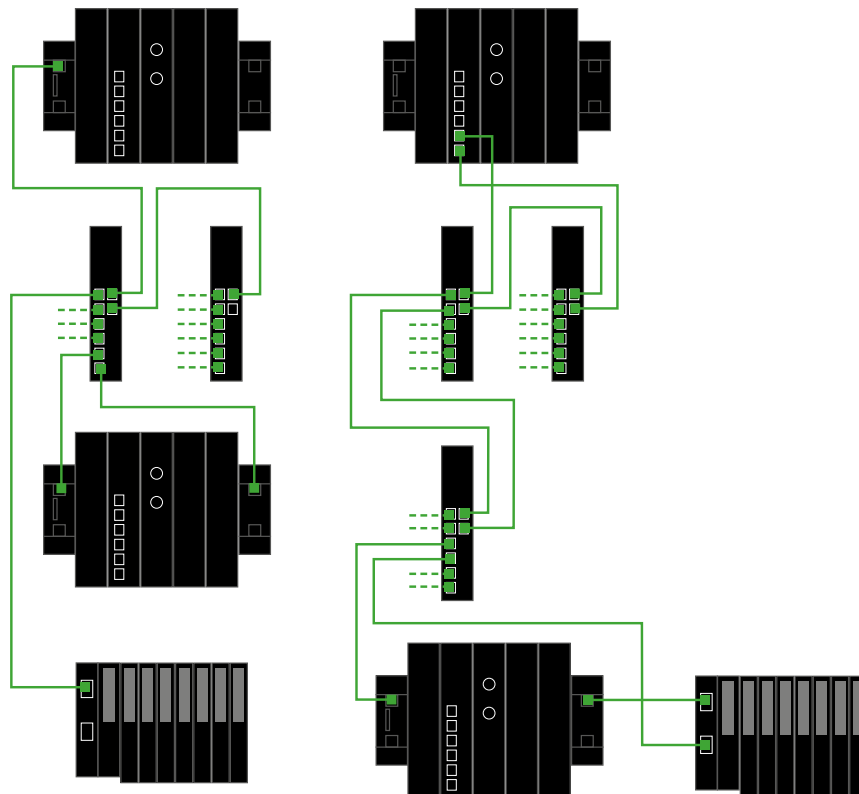

## Dimensional Drawings

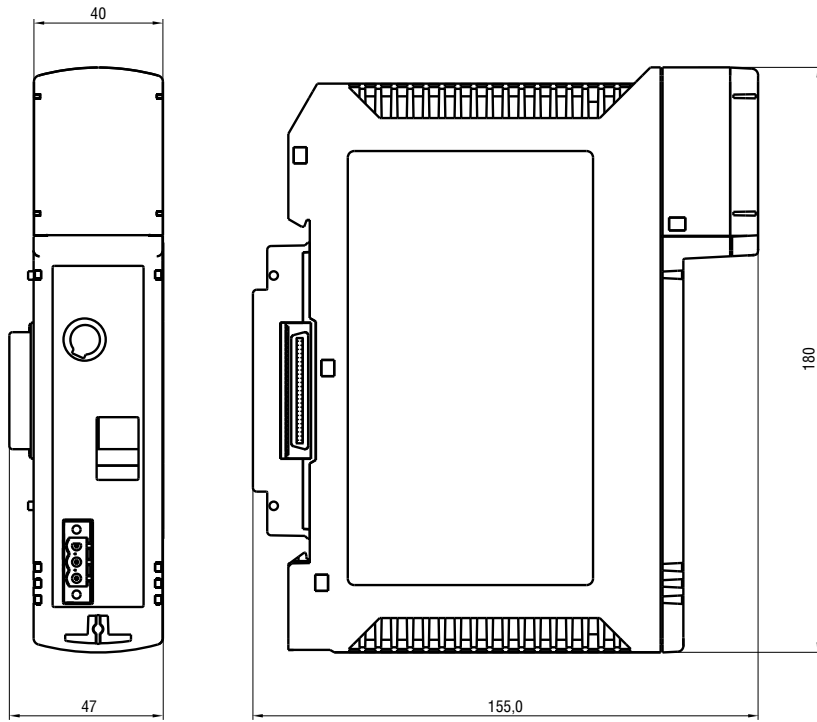

# EPSILON LD – IEC 61131-3 Development Software for REGUL Controllers



## Epsilon LD

Epsilon LD is an integrated software package that provides all the tools required for configuration, programming and maintenance of all the REGUL controllers. Having one package only enables you to flexibly use the most appropriate controller series in your project without having to learn new tools and approaches. Epsilon LD supports development of applications in the following languages:

- IEC 61131-3
  - FBD (Functional Block Diagram)
  - LD (Ladder Diagram / Ladder Logic)
  - ST (Structured Text)
  - IL (Instruction List)
  - SFC (Sequential Function Diagram)
- CFC (Continuous Function Chart)

### Network Scanner – Find all your controllers in the network for IP configuration

A specially developed tool, Network Scanner, is included into Epsilon LD to find all the REGUL controllers in your network, no matter what their network configuration is. Then the same tool can be used to configure IP addresses and names of the controllers.

### Abstraction – Simple to start with PLC development

Abstraction level in the Epsilon LD separates controller configuration from the programming part. This approach allows for a developer new to PLC programming or to the use of REGUL controllers, to have a faster start with the system.

### Visual PLC Editor

It is highly supportive to visualize the configuration of the system and have a clear understanding which rack contains which modules and visibly identify the state of the racks. To perform it, the software shows each system configuration in the visual editor, with drag-and-drop adjustments.

### Redundancy Configuration

As the redundancy is at the core of the REGUL controllers, it was important to have a convenient tool to set up and monitor redundancy state. The tool allows you to see the type of the redundancy used in the system in the Visual PLC Editor, as well as indicate controllers to be used as main and hot-standby, compare firmware and application used in each of them, and switch the control from one to another.

### Programming – Wide choice of languages to your taste

The modular structure of the projects in the Epsilon LD software supports the use of different languages more suitable to different parts of the application. IEC 61131-3 are integrated into the software and the developers can choose the preferred language for them. Additionally, there is support for CFC (Continuous Function Chart). Since the application could be split into modules running with a different speed, each of the modules can use its own language too.

### Online Software Update

One of the most distinguished features is the support of the live software update on the redundant systems without stopping them from the operation. When performing an update, the control is switched to the second controller while in hot-standby. Then, the application update is uploaded to the first controller and the control is switched back to it. After successful pickup of the new application, it is synchronized to the standby controller.

## Profiling

Each project in the Epsilon LD is developed in its own profile and you can keep as many as needed. Separate profiles allow you to get the same environment as when the application was developed. Reducing the need to search and fix library dependencies.

## Integrated Visualization

Oftentimes, the requirements for visualization are less than the use of a SCADA system. In those cases, developers can create an interface directly from Epsilon LD and download it to the controllers. There is support for two types – one is Target Visualization, when it is displayed on an HMI (for example, R400) or on a monitor connected to the CPU module; the second is Web Visualization available in corresponding versions of the CPU modules. In case of Web Visualization, a web server runs in the module supporting remote connection and remote display of the state and control of PLC in the defined interface.

## Integrated Debugger

Once the application is developed, use the debugger to go step-by-step through your application to ensure smooth and correct running.

## Remote Diagnostics and Maintenance

Design of the controller to be used in the locations that are difficult to reach or the travel takes plenty of time puts a special accent on the possibility to remotely diagnose and update controller. This is reached by the integrated tools in the Epsilon LD software that support collection of the diagnostic information, analysis of the operation, and update where necessary. This includes configuration of the I/O modules, update of the application, firmware update.

## Real-Time Operation

Before download to the controller, the application is compiled into a package for real-time operating system in the controller. Operation under it allows each REGUL controller to deliver stable and secure performance in the industrial environments.

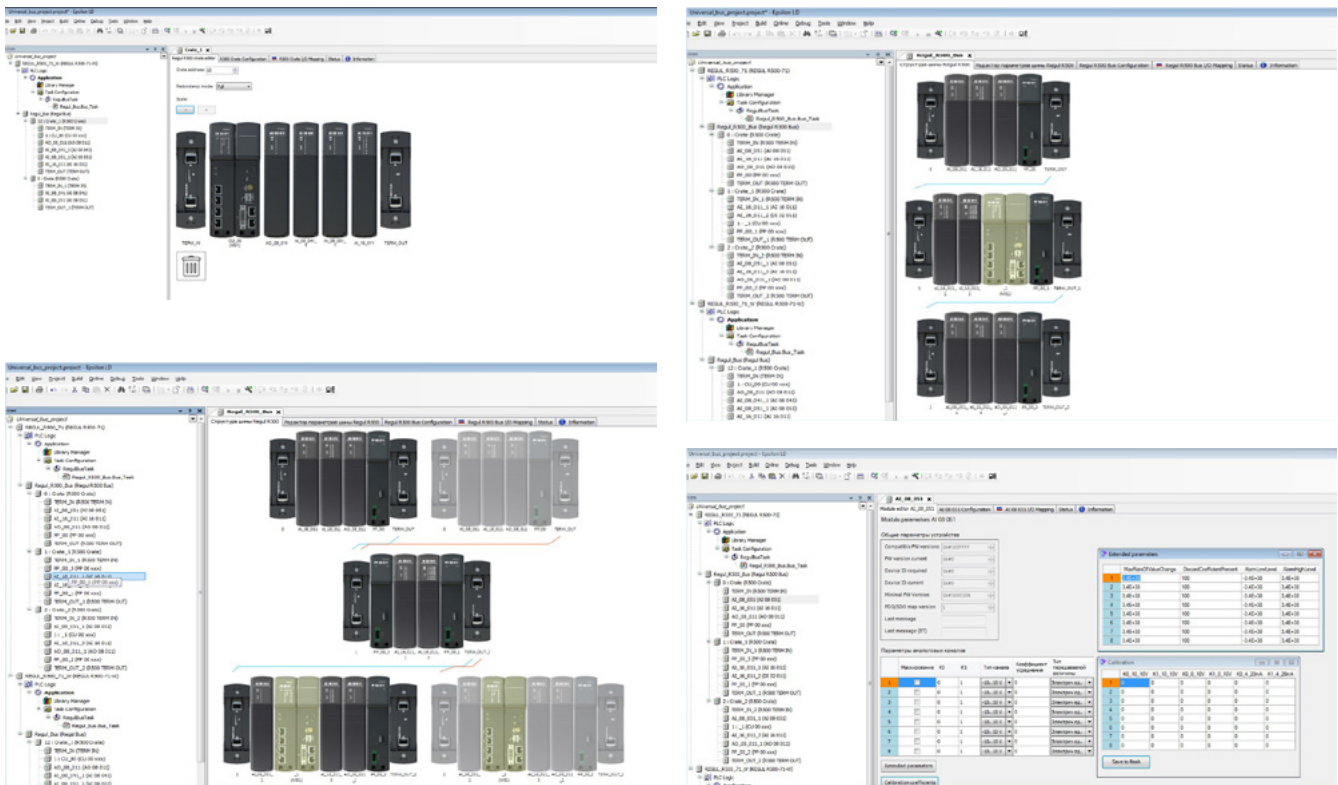

# AlfaRegul Integrated Control System (SCADA + HMI + PLC)



AlfaRegul Integrated Control System (ICS) is a complete integrated solution. The system combines SCADA and PLC in one package with one point of support. AlfaRegul ICS is designed for creating control systems of large production facilities with distinct breakdown by functional features as well as for building distributed control systems (DCS) with cascade regulation. AlfaRegul ICS is a single control tool of production processes that allows for reducing the time of commissioning of control circuits, minimizing operation risks and saving project investments.

AlfaRegul ICS meets in full all the requirements to a modern process control system.

## Designed for high productivity with an own NoSQL database

- Storage of parameter and event change history in the system's own high performance real-time database
- Real time data processing
  - 1,000,000 system configuration parameters
  - 1,000,000 changes per second
  - Up to 50,000 tags per one controller
  - Minimum application cycle time in redundant operation – 5 ms
- Data recording and storage:
  - Up to 2,000,000 stored parameters per server
  - Recording of up to 700,000 changes per second
- Reading of up to 1,500,000 changes per second
- SQL sampling up to 200,000 changes per second

## Highly scalable

- Up to 100 controllers per computation node
- Up to 50,000 tags per one controller
- Up to 50 workstations per computation node
- Up to 100 computation nodes in a system

## Integrated mechanisms for ensuring data integrity

- Data buffering in computation nodes prevents data loss during data transfer
- Possibility of multiple duplications of history databases

## Centralized development with powerful tools and object-oriented approach

- Adapted object-oriented information model of a facility Implementation of infrastructure functions of the system
- Remote configuration setup and downloads to workstations and to PLCs
- HMI scripting in JavaScript or Alpha. Om (internal programming language)
- Development of integrated visual solutions for operators
- Creation of own libraries for the graphical objects
- Support of 5 languages from the IEC 61131-3 standard
- Support of calculations and debugging in execution mode distributed databases and calculations

- Detection of connectivity and project errors at the phase of project compilation
- Project team work

#### Cross-platform and support of commonly used protocols

- Cross-platform format of the top system level: Windows or Unix OS families
- Use of external algorithms of any complexity for the calculation via integrated DLL libraries
- Support of OPC, SQL, and HART protocol families

#### Simple, reliable, and convenient process control

- Event and notification support
- Representation of process parameter charts and trends
- Possibility of activation of simulation and manual equipment control modes

#### Graphical visualization of production process

- Displaying of up 16,000 parameters in a mimic diagram with data change rate of 5 times per second
- Transition time between mimic diagrams – 0.4 sec
- Support of multi-monitor systems
- Web interface for remote access

#### Information safety

- Identification and authentication of access subjects
- Registration of safety events
- Integrity control of the project and components
- Implementation of client safety cluster (single access point to distributed workstations)
- Administration tools



**50 000**

tags per one  
controller



**100**

controllers  
per computation node



**50**

WKS per computation  
node

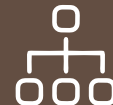

**100**

computation nodes  
in a system

- █ Backup at each system level
- █ Centralized administration of the whole system
- █ Remote configuration setup and loading for WKS
- █ Support of calculations in execution mode
- █ Scripting in JavaScript and Alpha.0m

- █ Storage of parameter and event change history in the system's own high performance real-time database
- █ Events and notifications
- █ Process parameter charts and trends
- █ Support of OPC, IEC, Modbus, SQL, or custom protocols



AlfaRegul integrated control system is based on the Alpha Platform software and REGUL RX00 PLCs.

### Alpha Platform SCADA

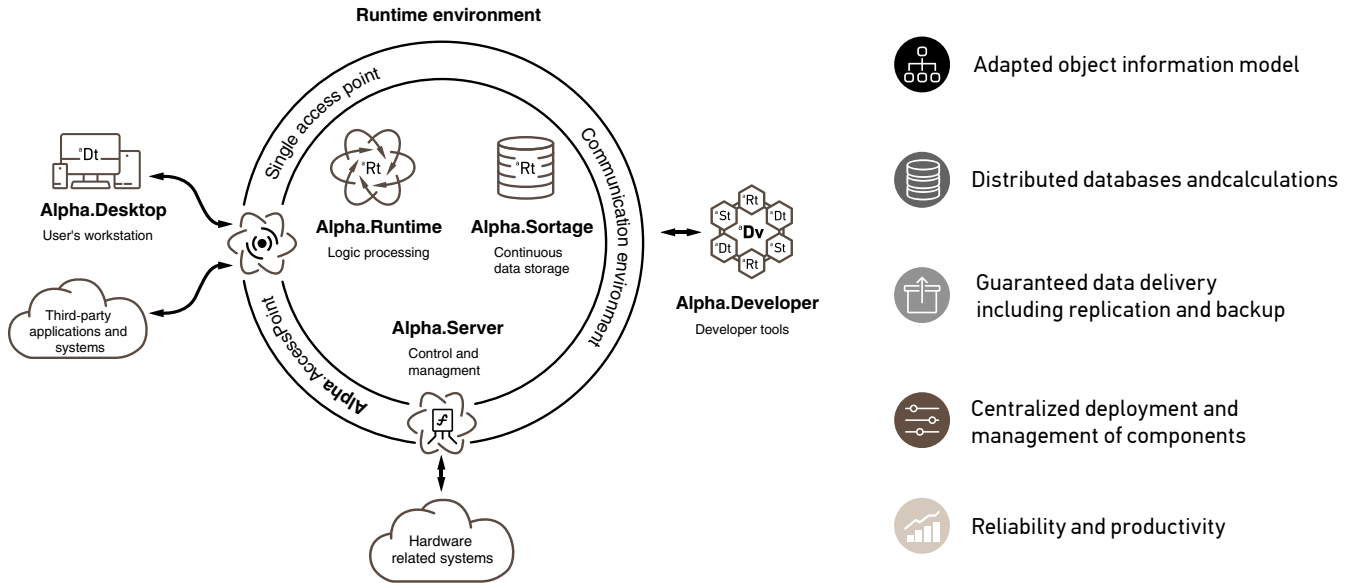

### Example of a Distributed Control System with AlfaRegul

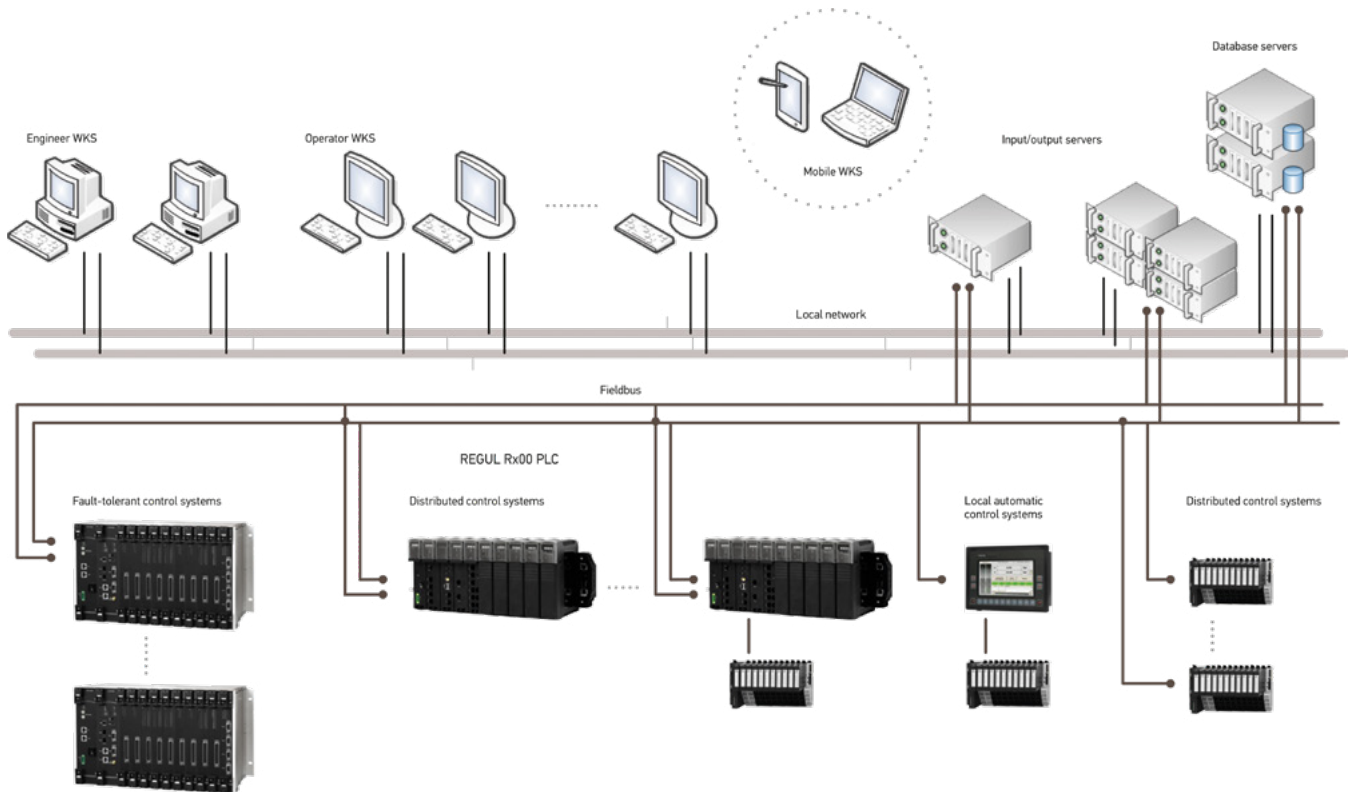

The system is flexibly configured according to the requirements of large and small enterprises in various industries.

### Example of structure for a local installation of AlfaRegul ICS

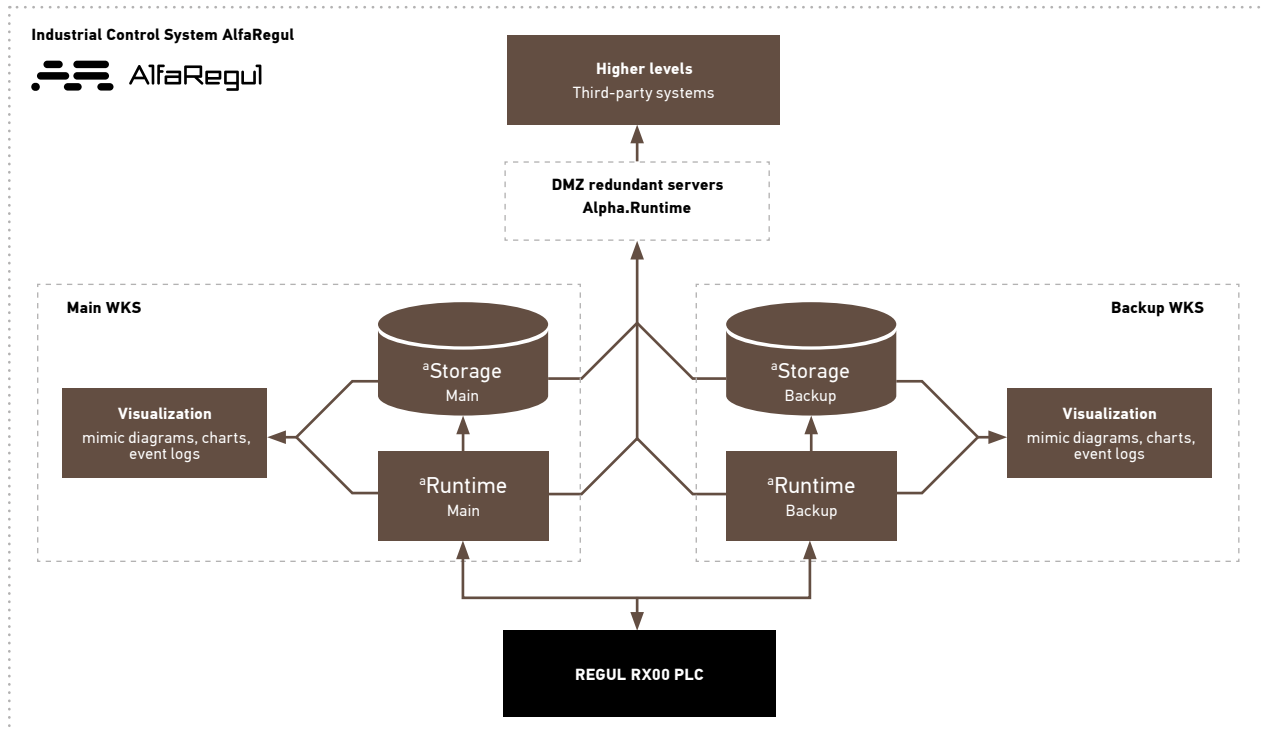

### Example of structure for a distributed configuration of AlfaRegul ICS

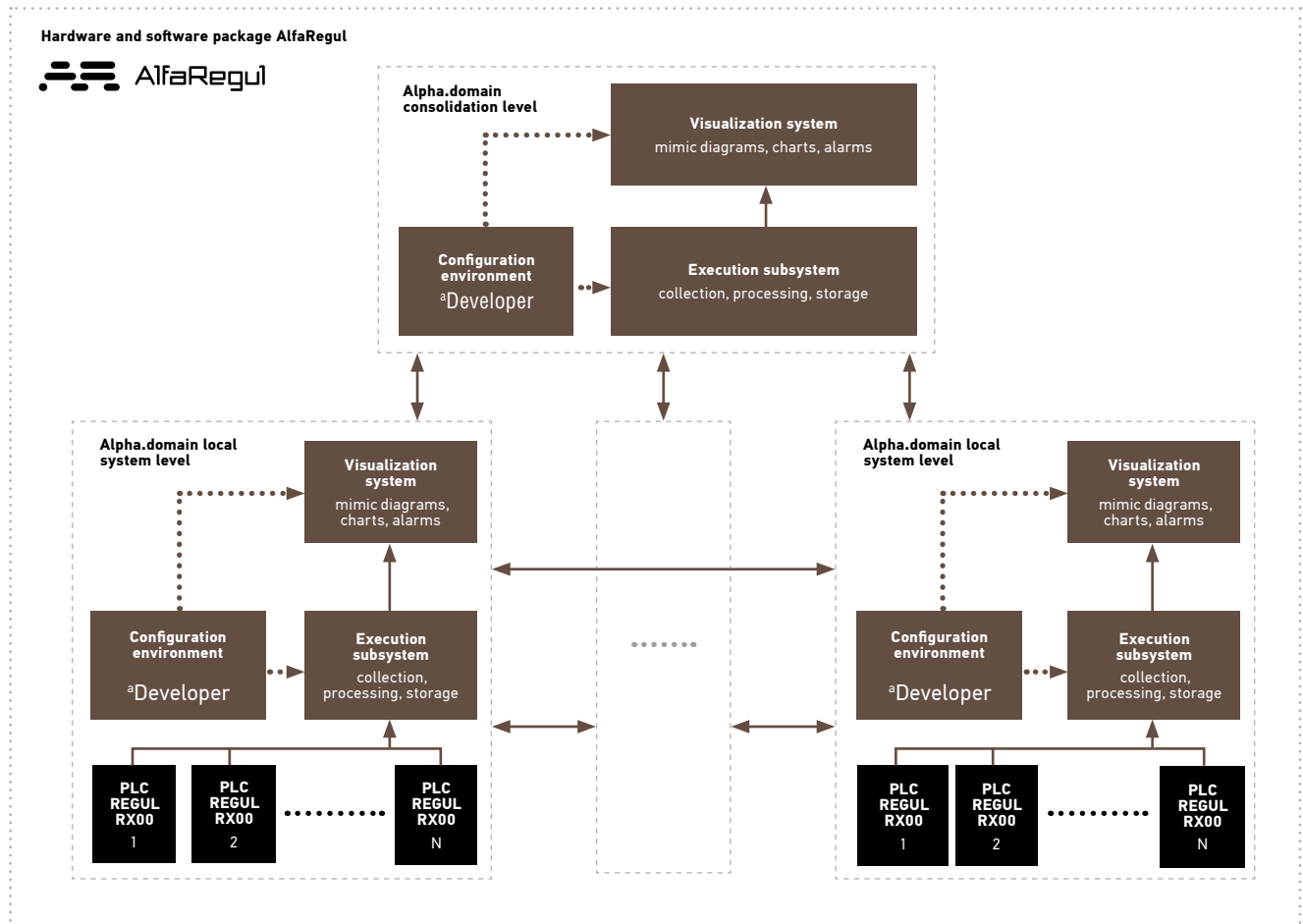

Example of a mimic diagram of a geographically distributed control system

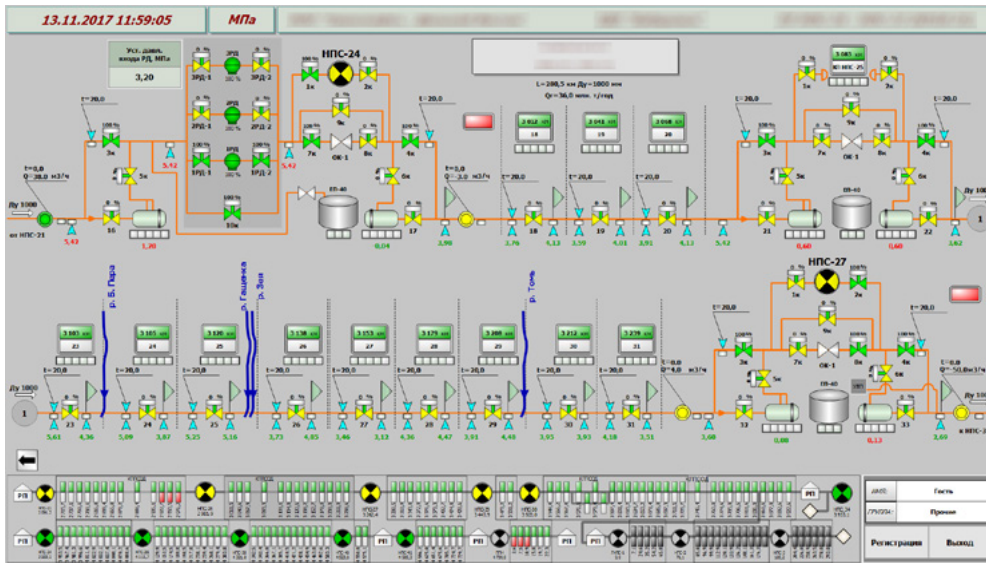

Trends and alarms

Сообщения

Режим отображения сообщений с фильтрацией по заданному объекту

Время появления	Сообщение	Важность
13.11.2017 11:45:12:216	КП 10. Задача 10. Минимумы кривые производимые (работает) (Успешно)	1
13.11.2017 11:45:12:216	КП 10. Задача 10. Минимумы кривые производимые (работает) (Успешно)	1
13.11.2017 11:45:12:216	КП 10. Интенсивность прибора С200-АСТТ (Успешно)	1
13.11.2017 11:45:12:216	КП 10. Интенсивность прибора С200-АСТТ (Успешно)	1
13.11.2017 11:45:12:216	КП 10. Задача 10. Минимумы кривые производимые (работает) (Успешно)	1
13.11.2017 11:45:12:216	КП 10. Задача 10. Дефект параметра группы В (Успешно)	1
13.11.2017 11:45:12:216	КП 10. Задача 10. Срабатывание пограничного значения (Успешно)	1
13.11.2017 11:45:12:216	КП 10. Интенсивность прибора на ПВД ВСУ (Успешно)	1
13.11.2017 11:45:12:216	КП 10. Интенсивность прибора С200-АСТТ (Успешно)	1
13.11.2017 11:45:12:216	КП 10. Задача 10. Минимумы кривые производимые (работает) (Успешно)	1
13.11.2017 11:45:12:216	КП 10. Задача 10. Дефект параметра группы В (Успешно)	1
13.11.2017 11:45:12:216	КП 10. Задача 10. Срабатывание пограничного значения (Успешно)	1
13.11.2017 11:45:12:216	КП 10. Минимумы кривые производимые (работает) (Успешно)	1
13.11.2017 11:45:12:216	КП 10. Интенсивность прибора С200-АСТТ (Успешно)	1
13.11.2017 11:45:12:216	КП 10. Интенсивность прибора на ПВД ВСУ (Успешно)	1
13.11.2017 11:45:12:216	КП 10. Задача 10. Минимумы кривые производимые (работает) (Успешно)	1
13.11.2017 11:45:12:216	КП 10. Задача 10. Дефект параметра группы В (Успешно)	1
13.11.2017 11:45:12:216	КП 10. Задача 10. Срабатывание пограничного значения (Успешно)	1
13.11.2017 11:45:12:216	КП 10. Минимумы кривые производимые (работает) (Успешно)	1
13.11.2017 11:45:12:216	КП 10. Интенсивность прибора С200-АСТТ (Успешно)	1
13.11.2017 11:45:12:216	КП 10. Задача 10. Минимумы кривые производимые (работает) (Успешно)	1
13.11.2017 11:45:12:216	КП 10. Задача 10. Дефект параметра группы В (Успешно)	1
13.11.2017 11:45:12:216	КП 10. Задача 10. Срабатывание пограничного значения (Успешно)	1
13.11.2017 11:45:12:216	КП 10. Минимумы кривые производимые (работает) (Успешно)	1



Graphic editor

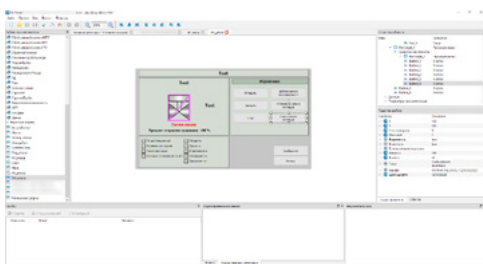

Access control configuration tool

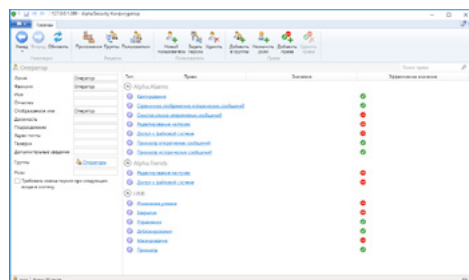

# TECHNICAL SUPPORT

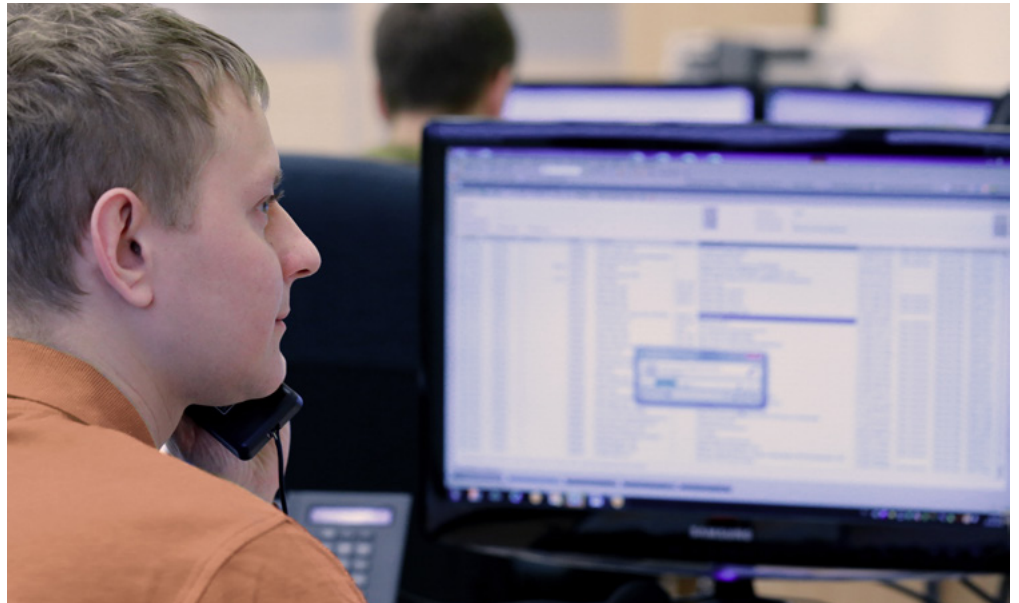

Professional interaction with the client at each stage is a key component of the high-quality service provided by GP Systems. A fast response to the client's needs helps the company to efficiently solve arising technical questions.

Technical support is provided via the [support.gp-systems.com](https://support.gp-systems.com) web portal. Company experts also perform all kinds of activities related to guarantee and post-guarantee servicing of the installed equipment and systems.





# TRAINING CENTER



To train support engineers of the customers, using Regul RX00 controllers, our group opened a specialized training center. Training courses on new equipment, key solutions, and GP Systems products are held on a regular basis.

Training is organized in the form of workshops with lectures and hands-on practice. The company's leading experts act as trainers. All the training stations are equipped with required equipment and connected to the systems, simulating real-life projects. In the course of the training, time is also given to individual studies and to the solution of technical issues important to the trainee's company.

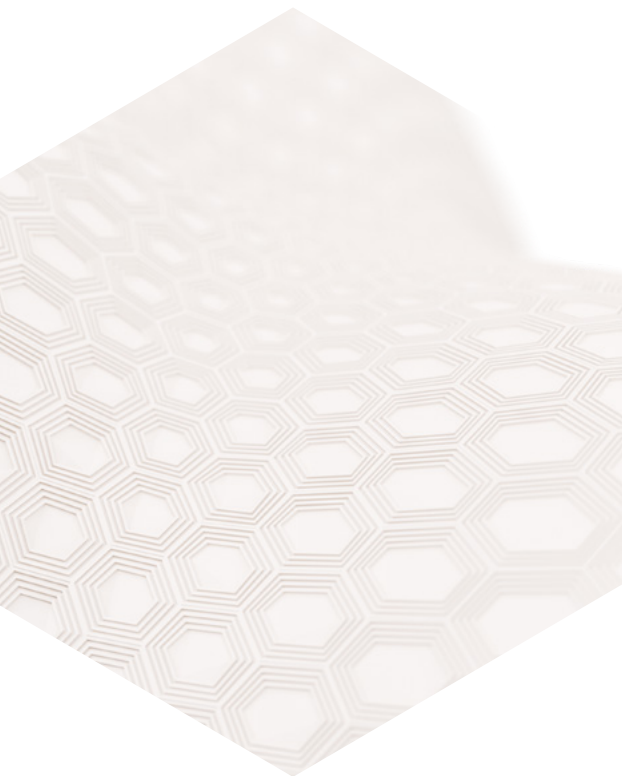





GP Systems GmbH  
Ochshäuser Str. 45,  
34123 Kassel, Germany  
tel.: +49 (561) 820 93350  
info@gp-systems.com  
www.gp-systems.com

